





Manual Motor Starters

Type Series M up to 45 kW (400 V AC)

Contents

Manual Motor Starter MS116	
0-16 A, 16/50 kA	6
Manual Motor Starter MS325	
0-25 A, 100 kA	8
Manual Motor Starters MS45x	
11-50 A, 25/50 kA	12
Manual Motor Starters MS49x	
11-50 A, 25/50/100 kA	12
Manual Motor Starters MOxxx	
up to 100 A, 25/50 kA	14
Starter Combinations with Manual Motor Starters	16
Busbar System smissline-S	
up to 200 A, 50 kA.....	18
Technical data, Short circuit switching tables	20
Dimension diagrams	28
Examples, applications	33

Manual Motor Starters and Motor Starter Combinations

Manual motor starters from ABB properly switch motors ON and OFF and protect them in case of overload and short circuit.

Thus, ABB's manual motor starter know-how increases the reliability and availability of applications thanks to the extremely quick short circuit cut-off in cases that could cause motor damage.

ABB motor starter combinations constitute a reliable, cost-efficient solution for all your motor protection needs, for examples in:

- General engineering and plants
- Industries
- Conveyor systems
- Chemical industries including process engineering
- Pharmaceutical industries
- Automation of buildings, e. g. in air-conditionings
- Environmental plants
- Power stations
- Fresh water and sewage plants
- Machine tools

Manual motor starters provide protection against:

- Overload
- Short circuit
- Phase failure
- Undervoltage

Fuseless protection saves costs and space and provides for quick reaction under short circuit condition, switching the motor off within 3 ms. It is therefore an easy to handle, cost effective protection solution.



Switching capabilities of ABB's manual motor starters

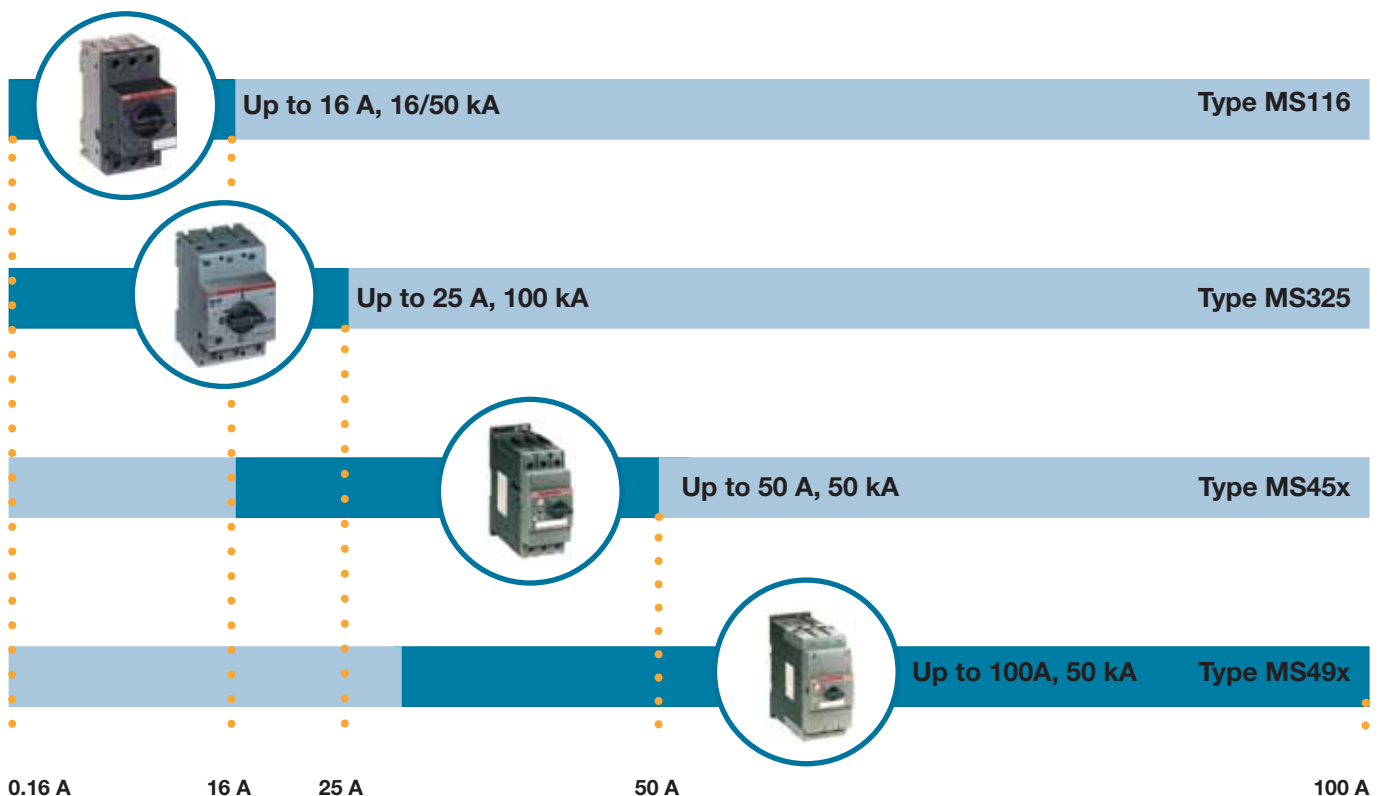

Manual Motor Starters from ABB

ABB offers a wide range of a manual motor starters providing highly efficient motor protection up to 100 A. The arc breaking capacity of the devices can reach up to 100 kA depending of the motor starter type used, without the necessity for any special upstream protection.

Thanks to its design MS116/325 are suitable for industrial applicatons as well as for domestic installations.

The device-types MS116/325 can be easily coordinated with the ABB MCB-system, which is used in installations for touch-proved enclosures and panels.

MS450 to MS497 are your best choice for high power applications. These models are used to power up large motors up to 45 kW.

Technical Data, Overview

Motorstarter type	MS116	MS325	MS45x	MS49x
I_n /A	16	25	50	100
I_{CS} /kA	16/30/50	50/100	25/50	25/50/100
Tripping class	10	10	10,20	10,20
Magnetic type only		●	●	●
Disconnect Capability, ref. IEC 60947-1	●	●	●	●
UL 508 type E		●	●	●

The types MS325 have the lowest “energy let through”-values on the market in case of short circuits. This way cables and the wiring are also protected optimally, providing for even higher safety.

Manual motor starters must be set to the rated motor demand. Higher current is needed at motor start-up. During the start-up period the manual motor starter will let the current go through and will not trip, following the pertaining international standards and curves for motor start and hold operation.

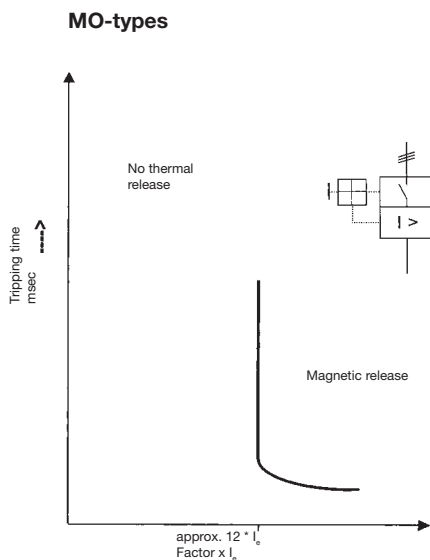

MSx Tripping curves

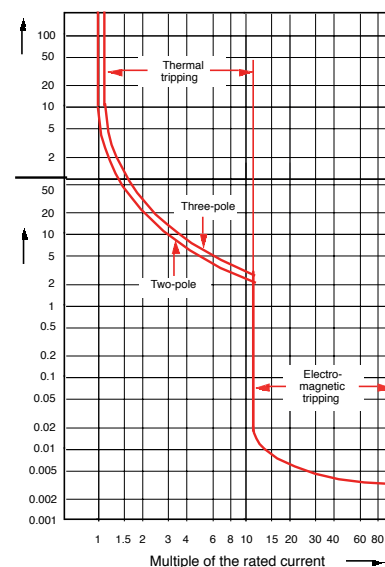

Manual Motor Starter MS116

Accessories

Ordering details

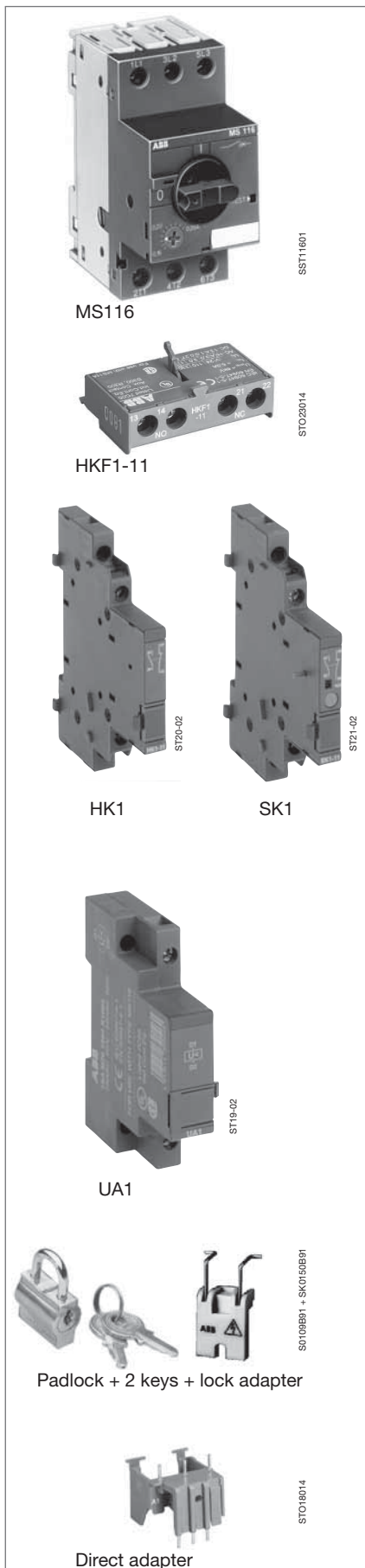

Type	Setting range	Order code	Weight/ piece kg	Packing Unit piece
	A...A			

MS116 with thermal and electromagnetic trips, short-circuit-proof up to 50 kA

MS116 - 0.16	0.10 ... 0.16	1SAM 250 000 R1001	0.268	1
MS116 - 0.25	0.16 ... 0.25	1SAM 250 000 R1002	0.268	1
MS116 - 0.4	0.25 ... 0.40	1SAM 250 000 R1003	0.268	1
MS116 - 0.63	0.40 ... 0.63	1SAM 250 000 R1004	0.268	1
MS116 - 1.0	0.63 ... 1.00	1SAM 250 000 R1005	0.268	1
MS116 - 1.6	1.00 ... 1.60	1SAM 250 000 R1006	0.268	1
MS116 - 2.5	1.60 ... 2.50	1SAM 250 000 R1007	0.268	1
MS116 - 4	2.50 ... 4.00	1SAM 250 000 R1008	0.268	1
MS116 - 6.3	4.00 ... 6.30	1SAM 250 000 R1009	0.268	1
MS116 - 10.0	6.30 ... 10.00	1SAM 250 000 R1010	0.268	1
MS116 - 12.0	8.00 ... 12.00	1SAM 250 000 R1012	0.268	1
MS116 - 16.0	10.00 ... 16.00	1SAM 250 000 R1011	0.268	1

Accessories

Type	Order code	Packing Unit piece
------	------------	--------------------------

Auxiliary switches, for front mounting ①

HKF1-11	1 NO + 1 NC	1SAM 201 901 R1001	1
---------	-------------	--------------------	---

Auxiliary switches with lead contacts, also to use with undervoltage release

HK1-20L	2 NO lead contacts	1SAM 201 902 R1004	1
---------	--------------------	--------------------	---

Auxiliary switches, lateral attachment at right

HK1-11	1 NO + 1 NC	1SAM 201 902 R1001	1
HK1-20	2 NO	1SAM 201 902 R1002	1
HK1-02	2 NC	1SAM 201 902 R1003	1

Shunt release, lateral mounting at the left side

AA1-24	24 V, 50/60 Hz	1SAM 201 910 R1001	1
AA1-110	110 V, 50/60 Hz	1SAM 201 910 R1002	1
AA1-230	200-240 V, 50/60 Hz	1SAM 201 910 R1003	1
AA1-400	350-415 V, 50/60 Hz	1SAM 201 910 R1004	1

Signal switch for general "tripped" signal, lateral attachment at right

SK1-11	1 NO + 1 NC	1SAM 201 903 R1001	1
SK1-20	2 NO	1SAM 201 903 R1002	1
SK1-02	2 NC	1SAM 201 903 R1003	1

Undervoltage release, lateral attachment at left

UA1-24	24 V, 50 Hz	1SAM 201 904 R1001	1
UA1-48	48 V, 50 Hz	1SAM 201 904 R1002	1
UA1-60	60 V, 50 Hz	1SAM 201 904 R1003	1
UA1-120	110 V 50 Hz/120 V 60 Hz	1SAM 201 904 R1004	1
UA1-208	208 V, 60 Hz	1SAM 201 404 R1008	1
UA1-230	230 V 50 Hz/240 V 60 Hz	1SAM 201 904 R1005	1
UA1-400	400 V, 50 Hz	1SAM 201 904 R1006	1
UA1-415	415 V 50 Hz/480 V 60 Hz	1SAM 201 904 R1007	1

Locking device (see also MS325, Page 9)

SA1	lock adapter	GJF1 101 903 R0001	1
SA2	padlock + 2 keys	GJF1 101 903 R0002	1
SA3	lock adapter + padlock + 2 keys	GJF1 101 903 R0003	1
FC116	fixing clip for screw mounting	1SAM 201 909 R1001	

Direct adapter, for wiring to contactors

BEA7/116	mini contactors B6/B7	1SBN 080 906 R1000	1
BEA16/116	contactors A9/A12/A16	1SBN 081 406 R1000	1
BEA26/116	contactors A26	1SBN 082 406 R1000	1

① Not suitable for panel mounting

Manual Motor Starter MS116

Accessories

Ordering details

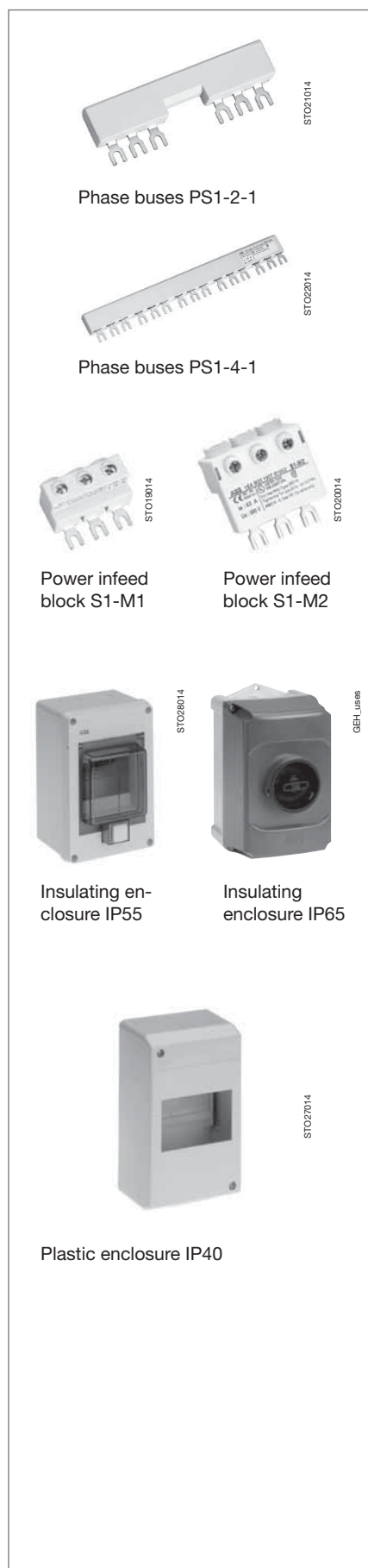

Accessories

Type	Order cod	Packing Unit/piece	Price
Phase buses for cross wiring MS116, 63 A, 690 V			
PS1-2-0 , for 2 devices without auxiliary switches	1SAM 201 906 R1002	10	
PS1-3-0 , for 3 devices without auxiliary switches	1SAM 201 906 R1003	10	
PS1-4-0 , for 4 devices without auxiliary switches	1SAM 201 906 R1004	10	
PS1-5-0 , for 5 devices without auxiliary switches	1SAM 201 906 R1005	10	
PS1-2-1 , for 2 devices with 1 auxiliary switch	1SAM 201 906 R1012	10	
PS1-3-1 , for 3 devices with 1 auxiliary switch	1SAM 201 906 R1013	10	
PS1-4-1 , for 4 devices with 1 auxiliary switch	1SAM 201 906 R1014	10	
PS1-5-1 , for 5 devices with 1 auxiliary switch	1SAM 201 906 R1015	10	
PS1-2-2 , for 2 devices with 2 auxiliary switches	1SAM 201 906 R1022	10	
PS1-3-2 , for 3 devices with 2 auxiliary switches	1SAM 201 906 R1023	10	
PS1-4-2 , for 4 devices with 2 auxiliary switches	1SAM 201 906 R1024	10	
PS1-5-2 , for 5 devices with 2 auxiliary switches	1SAM 201 906 R1025	10	
Power infeed blocks, 63 A, 690 V, stranded 25 mm², flexible 16 mm²			
S1-M1 , flat	1SAM 201 907 R1001	10	
S1-M2 , high	1SAM 201 907 R1002	10	
Cover for phase busses			
BS1-3	1SAM 201 908 R1001	50	
Insulating enclosure IP65, with rotary handle, triple lockable in Off position, with N- und PE-terminal, for Manual Motor Starter			
IB116-G , Twist knob black	1SAM 201 911 R1000	1	
IB116-Y , Twist knob red/yellow	1SAM 201 911 R1001	1	
Insulating enclosure, light grey IP55 with cover, including DIN rail for manual motor starter or line protection devices			
QES4/3N , for 4 modules, 72 mm	GHL 111 2304 R0013		
QES6/3N , for 6 modules, 108 mm	GHL 111 2306 R0013		
QES10/3N , for 10 modules, 180 mm	GHL 111 2310 R0013		
Set of neutral and earth terminals			
SMO4 , for QES 4/3 N	GHL 430 1910 R0004		
SMO6 , for QES 6/3 N	GHL 430 1910 R0006		
SMO10 , for QES 10/3 N	GHL 430 1910 R0010		
Plastic enclosure, light grey, IP40 in panel design, including DIN rail			
PCD4N , for 4 modules, 72 mm	GHS 270 1921 R0004		
PCD6N , for 6 modules, 108 mm	GHS 270 1921 R0006		
PCD8N , for 8 modules, 144 mm	GHS 270 1921 R0008		
Switch cubicle mounting kit IP65, with axial extension triple lockable in Off position, locked in On position			
OHB2AJM , Twist knob black	1SCA 022 384 R6940	1	
OHY2AJM , Twist knob red/yellow	1SCA 022 384 R7080	1	
OXS5X85 , axis 85 mm	1SCA 022 347 R3570	1	
OXS5X105 , axis 105 mm	1SCA 022 347 R3650	1	
OXS5X130 , axis 130 mm	1SCA 022 353 R4540	1	
OXS5X180 , axis 180 mm	1SCA 022 353 R4620	1	
MSMN , driver ①	1SAM 101 923 R0001	1	
MSOX , driver spindle 32 mm ②	1SAM 101 924 R0001	1	
Door mounting kit IP65, Lockable in Off-position			
DMS116-G , Twist knob black	1SAM 201 912 R1000	1	
DMS116-Y , Twist knob red/yellow	1SAM 201 912 R1001	1	

① For accommodating spindle and attachment to manual motor starter

② Is screwed directly onto the manual motor starter

Manual Motor Starter MS325

Ordering details



MS325

SST01487

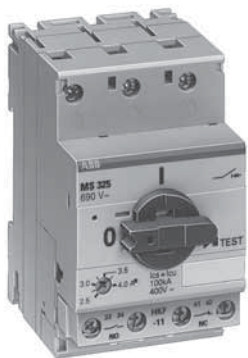

MS325 with auxiliary contacts HKF-11 front mounting

SST 02899



2CDC 241 008 F04



2CDC 241 004 F04

Type	Setting range	Order code	Weight/ piece kg	Packing Unit piece	Price
	A...A				

MS325 with thermal and electromagnetic trips, short-circuit-proof up to 100 kA

MS325 – 0.16	0.10 ... 0.16	1SAM 150 000 R1001	0.347	1	
MS325 – 0.25	0.16 ... 0.25	1SAM 150 000 R1002	0.347	1	
MS325 – 0.4	0.25 ... 0.40	1SAM 150 000 R1003	0.347	1	
MS325 – 0.63	0.40 ... 0.63	1SAM 150 000 R1004	0.347	1	
MS325 – 1	0.63 ... 1.00	1SAM 150 000 R1005	0.347	1	
MS325 – 1.6	1.00 ... 1.60	1SAM 150 000 R1006	0.347	1	
MS325 – 2.5	1.60 ... 2.50	1SAM 150 000 R1007	0.347	1	
MS325 – 4	2.50 ... 4.00	1SAM 150 000 R1008	0.347	1	
MS325 – 6.3	4.00 ... 6.30	1SAM 150 000 R1009	0.347	1	
MS325 – 9	6.30 ... 9.00	1SAM 150 000 R1010	0.347	1	
MS325 – 12.5	9.00 ... 12.50	1SAM 150 000 R1011	0.347	1	
MS325 – 16	12.50 ... 16.00	1SAM 150 000 R1012	0.347	1	
MS325 – 20	16.00 ... 20.00	1SAM 150 000 R1013	0.347	1	
MS325 – 25	20.00 ... 25.00	1SAM 150 000 R1014	0.347	1	

MS325 with thermal and electromagnetic trips, short-circuit-proof up to 100 kA, with auxiliary switch 1 NO + 1 NC front mounted

MS325 – 0.16	0.10 ... 0.16	1SAM 150 005 R0001	0.359	1	
MS325 – 0.25	0.16 ... 0.25	1SAM 150 005 R0002	0.359	1	
MS325 – 0.4	0.25 ... 0.40	1SAM 150 005 R0003	0.359	1	
MS325 – 0.63	0.40 ... 0.63	1SAM 150 005 R0004	0.359	1	
MS325 – 1	0.63 ... 1.00	1SAM 150 005 R0005	0.359	1	
MS325 – 1.6	1.00 ... 1.60	1SAM 150 005 R0006	0.359	1	
MS325 – 2.5	1.60 ... 2.50	1SAM 150 005 R0007	0.359	1	
MS325 – 4	2.50 ... 4.00	1SAM 150 005 R0008	0.359	1	
MS325 – 6.3	4.00 ... 6.30	1SAM 150 005 R0009	0.359	1	
MS325 – 9	6.30 ... 9.00	1SAM 150 005 R0010	0.359	1	
MS325 – 12.5	9.00 ... 12.50	1SAM 150 005 R0011	0.359	1	
MS325 – 16	12.50 ... 16.00	1SAM 150 005 R0012	0.359	1	
MS325 – 20	16.00 ... 20.00	1SAM 150 005 R0013	0.359	1	
MS325 – 25	20.00 ... 25.00	1SAM 150 005 R0014	0.359	1	

Auxiliary switches, for front mounting ①

HKF-11	1 NO + 1 NC	1SAM 101 928 R0001	0.020	10	
HKF-20	2 NO	1SAM 101 928 R0002	0.020	10	

Auxiliary switches, lateral attachment at left, max. 2 pieces attachable ② ③

HKF-11	1 NO + 1 NC	1SAM 101 901 R0001	0.031	10	
HKF-20	2 NO ④	1SAM 101 901 R0002	0.031	10	
HKF-02	2 NC	1SAM 101 901 R0003	0.031	10	

Signal switch for general "tripped" signal, lateral attachment at the left max. 1 piece attachable

SK-11	1 NO + 1 NC	1SAM 101 904 R0003	0.031	10	
-------	-------------	--------------------	-------	----	--

UL 508 Type E Accessories

S3-M3	High insulation infeed block	1SAM 101 938 R0004	0.030	10	
-------	------------------------------	--------------------	-------	----	--

Signal switch for short circuit tripping, lateral attachment at right

CK-11	1 NO + 1 NC	1SAM 101 943 R0001	0.030	10	
-------	-------------	--------------------	-------	----	--

Manual Motor Starters MS325

Accessories

Ordering details

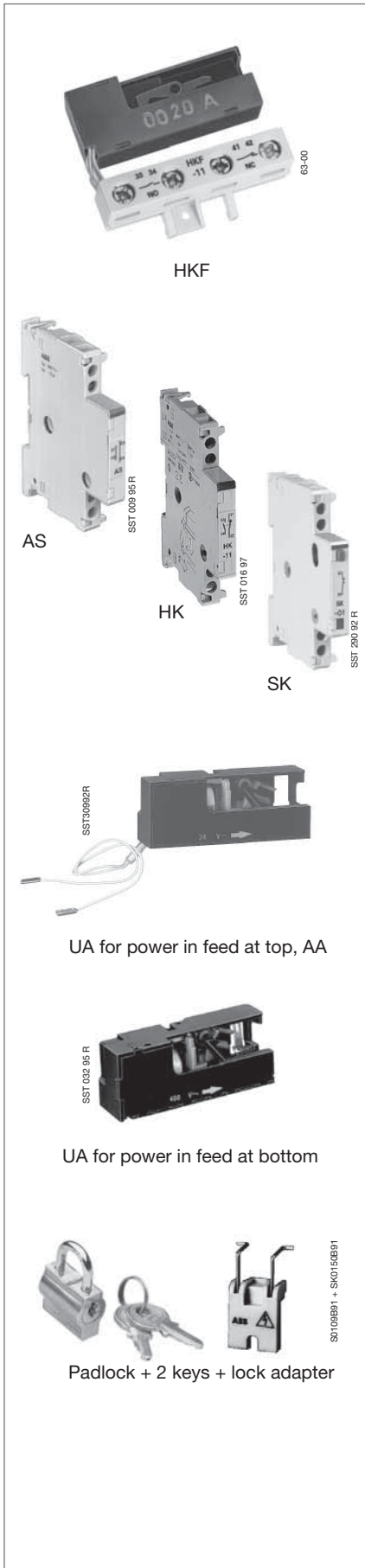

Retrofittable accessories

These parts can be procured in addition to the **MS325**; they must be installed by the user.

Type	Setting range	Order code	Weight/ piece kg	Packing Unit piece	Price
------	---------------	------------	------------------------	--------------------------	-------

Auxiliary switches, for front mounting ①

HKF-11	1 NO + 1 NC	1SAM 101 928 R0001	0.020	10	
HKF-20	2 NO	1SAM 101 928 R0002	0.020	10	

Auxiliary switches, lateral attachment at left, max. 2 pieces attachable ② ③

HK-11	1 NO + 1 NC	1SAM 101 901 R0001	0.031	10	
HK-20	2 NO ④	1SAM 101 901 R0002	0.031	10	
HK-02	2 NC	1SAM 101 901 R0003	0.031	10	

Signal contact for general "tripped" signal, lateral attachment at the left max. 1 piece attachable

SK-11	1 NO + 1 NC	1SAM 101 904 R0003	0.031	10	
--------------	-------------	---------------------------	-------	----	--

Undervoltage release, slide-in ⑤

UA , power infeed at bottom , ⑥ U _c 400 V~		1SAM 101 902 R0400	0.0210		
UAF , power infeed at top , resp. connection U _c of external voltage	24 V~	1SAM 101 903 R0024	0.0210		
	48 V~	1SAM 101 903 R0048	0.0210		
	60 V~	1SAM 101 903 R0060	0.0210		
	110 V~	1SAM 101 903 R0110	0.0210		
	230 V~	1SAM 101 903 R0230	0.0210		
	400 V~	1SAM 101 903 R0400	0.0210		
	415 V~	1SAM 101 903 R0415	0.0210		
	500 V~	1SAM 101 903 R0500	0.0210		

Open circuit shunt release, slide-in ⑦

AA	24 ... 60 V AC/DC	1SAM 101 909 R0001	0.02	10	
AA	110... 240 V AC/DC	1SAM 101 909 R0002	0.02	10	

Terminal support, lateral attachment at left to MS325, HK and SK

AS , for UA, AA or as N/LS terminal	1SAM 101 905 R0001	0.031	10	
--	---------------------------	-------	----	--

Locking device for MS325

SA1 , lock adapter	GJF1 101 903 R0001	0.004	10	
SA2 , padlock + 2 keys	GJF1 101 903 R0002	0.004	10	
SA3 , lock adapter + padlock + 2 keys	GJF1 101 903 R0003	0.050	1	

Printadapter, for soldering on electronic plates

PA25 , for MS325 and 2 aux. contacts	1SAM 101 933 R0001	0.030	1 kit	
--	---------------------------	-------	-------	--

① Not simultaneously with UA/UA and AA, not suitable for distributor installation

② Max. 1 piece in conjunction with SK. SK must be mounted on first position

③ Pre-mating normally open contacts

④ Can be used together with UAF (power infeed at top) for safety circuit with Emergency Stop button (further information available on request)

⑤ Other voltages, in particular DC, on request

⑥ In particular if used with socket busbar system smissline-S (see Page 19)

⑦ Recommendation: Connection of external voltage via terminal support AS

Manual Motor Starters MS325

Accessories

Ordering details



Accessories

Type	Order code	Weight/ piece kg	Packing unit piece	Price
Phase buses for cross wiring MS325, 63 A, 690 V				
PS3-2-0, for 2 dev., without aux. switch	1SAM 101 937 R0012		10	
PS3-3-0, for 3 dev., without aux. switch	1SAM 101 937 R0013		10	
PS3-4-0, for 4 dev., without aux. switch	1SAM 101 937 R0014		10	
PS3-5-0, for 5 dev., without aux. switch	1SAM 101 937 R0015		10	
PS3-2-1, for 2 dev., with 1 aux. switch	1SAM 101 937 R0022		10	
PS3-3-1, for 3 dev., with 1 aux. switch	1SAM 101 937 R0023		10	
PS3-4-1, for 4 dev., with 1 aux. switch	1SAM 101 937 R0024		10	
PS3-5-1, for 5 dev., with 1 aux. switch	1SAM 101 937 R0025		10	
PS3-2-2, for 2 dev., with 2 aux. switches	1SAM 101 937 R0032		10	
PS3-4-2, for 4 devices, with 2 aux. swit.	1SAM 101 937 R0034		10	
Power infeed blocks, 63 A, 690 V, stranded 25 mm², flexible 16 mm²				
S3- M1, flat	1SAM 101 938 R0001		10	
S3- M2, high	1SAM 101 938 R0002		10	
Cover for busbars (for not used poles)				
BS3-3	1SAM 101 938 R0003		50	
Insulating enclosure IP65 with rotary handle, triple lockable in Off position, with N- und PE-terminal, for Manual Motor Starter				
IB325-G, Twist knob black	1SAM 101 940 R1000	1		
IB325 Y, Twist knob red/yellow	1SAM 101 940 R1001	1		
Insulating enclosure, light grey IP55 with cover, including DIN rail for manual motor starter or line protection devices				
QES4/3N, for 4 modules, 72 mm	GHL 111 2304 R0013			
QES6/3N, for 6 modules, 108 mm	GHL 111 2306 R0013			
QES10/3N, for 10 modules, 180 mm	GHL 111 2310 R0013			
Set of neutral and earth terminals				
SMO4, for QES 4/3 N	GHL 430 1910 R0004			
SMO6, for QES 6/3 N	GHL 430 1910 R0006			
SMO10, for QES 10/3 N	GHL 430 1910 R0010			
Plastic enclosure, light grey, IP40 in panel design, including DIN rail				
PCD4N, for 4 modules, 72 mm	GHS 270 1921 R0004			
PCD6N, for 6 modules, 108 mm	GHS 270 1921 R0006			
PCD8N, for 8 modules, 144 mm	GHS 270 1921 R0008			

Manual Motor Starters MS325

Accessories

Ordering details



Switch cubicle mounting kit

2CDC 243 008 F005



Door mounting kit

2CDC 241 001 F003

Accessories

Type	Order code	Weight/ piece kg	Packing unit piece	Price
Switch cubicle mounting kit IP65, with axial extension triple lockable in Off position, locked in On position				
OHB2AJM , Twist knob black	1SCA 022 384 R6940		1	
OHY2AJM , Twist knob red/yellow ③	1SCA 022 384 R7080		1	
OXS5X 85 , axis 85 mm	1SCA 022 347 R3570		1	
OXS5X105 , axis 105 mm	1SCA 022 347 R3650		1	
OXS5X130 , axis 130 mm	1SCA 022 353 R4540		1	
OXS5X180 , axis 180 mm	1SCA 022 353 R4620		1	
MSMN , driver ①	1SAM 101 923 R0001		1	
MSOX , driver spindle 32 mm ②	1SAM 101 924 R0001		1	
Direct adapter MS325 ④				
BEA7/325 , direct adapter MS325 to B6/B7	1SBN 080 906 R1001	0.021	10	
BEA16/325 , direct adapter MS325 to A9/A12/A16	1SBN 081 406 R1001	0.031	10	
BEA26/325 , direct adapter MS325 to A26	1SBN 082 406 R1001	0.031	10	
Door mounting kit IP65, Lockable in Off-position				
DMS325-G , grey handle	1SAM 101 941 R1000		1	
DMS325-Y , red/yellow handle	1SAM 101 941 R1001		1	

① For accommodating spindle and attachment to manual motor starter

② Is screwed directly onto the manual motor starter

③ Only suitable for MS325

④ See also page 34

Manual Motor Starters MS4xx

Ordering details



MS45x

SST02198



MS49x

SST01898



MS495 with A95
connected via BEA 110/495

ST14-02



MS495 with auxiliary switch
HKS4-02 and open-circuit shunt
release AA4 in addition to termi-
nal shroud KA495C

SST 09498

Type	Setting range	Order code	Weight / piece kg	Packing unit piece	Price
	A . . . A				

MS450 with thermal and electromagnetic trips, tripping class 10, short-circuit-proof up to 50 kA ①

MS450 – 16	11 ... 16	1SAM 450 000 R1001	0.96	1	
MS450 – 20	14 ... 20	1SAM 450 000 R1002	0.96	1	
MS450 – 25	18 ... 25	1SAM 450 000 R1003	0.96	1	
MS450 – 32	22 ... 32	1SAM 450 000 R1004	0.96	1	
MS450 – 40	28 ... 40	1SAM 450 000 R1005	0.96	1	
MS450 – 45	36 ... 45	1SAM 450 000 R1006	0.96	1	
MS450 – 50	40 ... 50	1SAM 450 000 R1007	0.96	1	

MS495 with thermal and electromagnetic trips, tripping class 10, short-circuit-proof up to 50 kA ①

MS495 – 40	28 ... 40	1SAM 550 000 R1005	2.1	1	
MS495 – 50	36 ... 50	1SAM 550 000 R1006	2.1	1	
MS495 – 63	45 ... 63	1SAM 550 000 R1007	2.1	1	
MS495 – 75	57 ... 75	1SAM 550 000 R1008	2.1	1	
MS495 – 90	70 ... 90	1SAM 550 000 R1009	2.1	1	
MS495 – 100	80 ... 100 ②	1SAM 550 000 R1010	2.1	1	

MS497 with thermal and electromagnetic trips, tripping class 10, short-circuit-proof up to 100 kA ①

MS497 – 16	11 ... 16	1SAM 580 000 R1001	2.1	1	
MS497 – 20	14 ... 20	1SAM 580 000 R1002	2.1	1	
MS497 – 25	18 ... 25	1SAM 580 000 R1003	2.1	1	
MS497 – 32	22 ... 32	1SAM 580 000 R1004	2.1	1	
MS497 – 40	28 ... 40	1SAM 580 000 R1005	2.1	1	
MS497 – 50	36 ... 50	1SAM 580 000 R1006	2.1	1	
MS497 – 63	45 ... 63	1SAM 580 000 R1007	2.1	1	
MS497 – 75	57 ... 75	1SAM 580 000 R1008	2.1	1	
MS497 – 90	70 ... 90	1SAM 580 000 R1009	2.1	1	
MS497 – 100	80 ... 100 ②	1SAM 580 000 R1010	2.1	1	

MS451 with thermal and electromagnetic trips, tripping class 20, for heavy start short-circuit-proof up to 50 kA ①

MS451 – 16	11 ... 16	1SAM 470 000 R1001	0.96	1	
MS451 – 20	14 ... 20	1SAM 470 000 R1002	0.96	1	
MS451 – 25	18 ... 25	1SAM 470 000 R1003	0.96	1	
MS451 – 32	22 ... 32	1SAM 470 000 R1004	0.96	1	
MS451 – 40	28 ... 40	1SAM 470 000 R1005	0.96	1	
MS451 – 45	36 ... 45	1SAM 470 000 R1006	0.96	1	
MS451 – 50	40 ... 50	1SAM 470 000 R1007	0.96	1	

MS496 with thermal and electromagnetic trips, tripping class 20, for heavy start short-circuit-proof up to 100 kA ①

MS496 – 40	28 ... 40	1SAM 570 000 R1005	2.1	1	
MS496 – 50	36 ... 50	1SAM 570 000 R1006	2.1	1	
MS496 – 63	45 ... 63	1SAM 570 000 R1007	2.1	1	
MS496 – 75	57 ... 75	1SAM 570 000 R1008	2.1	1	
MS496 – 90	70 ... 90	1SAM 570 000 R1009	2.1	1	
MS496 – 100	80 ... 100 ②	1SAM 570 000 R1010	2.1	1	

Direct adapter for wiring MS450 - MS497 to contactors

Type	Order code	Weight / piece kg	Packing unit piece	Price
BEA40/450, direct adapter MS450 to A30/A40	1SBN 083 206 R1000	0.061	1	
BEA50/450, direct adapter MS450 to A50 plate	1SBN 083 506 R1000	0.062	1	
BEA75/495, direct adapter MS495-497 to A50/63/75	1SBN 084 106 R1000	0.120	1	
BEA110/495, direct adapter MS495-497 to A95/A110	1SBN 084 506 R1000	0.124	1	

① See table on Page 24, ② Max. motor current 95 A

Manual Motor Starters MS4xx

Accessories

Ordering details



Auxiliary switch HK4-11



Auxiliary switch HKS4-02



Pilot switch SK4-22



Open-circuit shunt release AA4



Undervoltage release UA4-HK

Retrofittable accessories

These parts may be procured in addition to the MS4xx. They must be mounted by the user.

Type		Order code	Weight/ piece kg	Packing unit piece	Price
Auxiliary switches, for front mounting					
HK4-11,	1 NO + 1NC	1SAM 401 901 R1001	0.02	10	
HK4-W,	1 Changeover	1SAM 401 901 R1002	0.02	10	
Auxiliary switches, for lateral attachment at left, max. 1 mountable					
HKS4-11,	1 NO + 1 NC	1SAM 401 902 R1001	0.03	2	
HKS4-20,	2 NO	1SAM 401 902 R1002	0.03	2	
HKS4-02,	2 NC	1SAM 401 902 R1003	0.03	2	
Signal switch for separate signalling acc. UL508 type E, lateral attachment at left 2 contacts for short circuit tripping and 2 contacts for general tripping					
SK4-22	2 NO + 2 NC	1SAM 401 904 R 1001	0.07	1	
Undervoltage release, for lateral attachment at right					
UA4,	U _e 24 V 50 Hz	1SAM 401 905 R1004	0.12	1	
UA4,	110 V 50 Hz	1SAM 401 905 R1001	0.12	1	
UA4,	230 V 50 Hz / 240 V 60 H	1SAM 401 905 R1002	0.12	1	
UA4,	400 V 50 Hz	1SAM 401 905 R1003	0.12	1	
Undervoltage release with pre-mating auxiliary switch 2 NO, for lateral attachment at right					
UA4-HK,	U _e 230 V 50 Hz / 240 V 60 Hz	1SAM 401 906 R1001	0.13	1	
UA4-HK,	400 V 50 Hz	1SAM 401 906 R1002	0.13	1	
Shunt release, lateral mounting at the left side ⑤					
AA4,	20-70 V, 50/60 Hz/DC	1SAM 401 907 R1001	0.11	1	
AA4,	70-190 V, 50/60 Hz/DC	1SAM 401 907 R1002	0.11	1	
AA4,	190-330 V, 50/60 Hz/DC	1SAM 401 907 R1003	0.11	1	
AA4,	330-500 V, 50/60 Hz/DC	1SAM 401 907 R1004	0.11	1	
Terminal shroud, for additional shock-hazard protection					
KA450,	for MS45x ①	1SAM 401 908 R1001	0.01	1	
KA495,	for MS49x ①	1SAM 501 901 R1001	0.01	1	
KA495C,	for MS49x ②	1SAM 501 902 R1001	0.03	1	
Terminal insulation barrier,					
DX495	necessary for UL 508E, MS49x-Starter	1SAM 401 912 R1001			
Scale cover, lead-sealable					
SA450,	for MS45x ③	1SAM 401 909 R1001	0.007	1 set	
Disconnecter module, for producing a visible gap, lockable					
TB450,	for MS45x	1SAM 401 910 R1001	0.30	1	
Phase busses MS45x, 108 A, 690 V					
PS4-2	without HK, for 2 devices	1SAM 401 911 R1001			
PS4-3	without HK, for 3 devices	1SAM 401 911 R1002			
PS4-4	without HK, for 4 devices	1SAM 401 911 R1003			
PS4-2	with HK, for 2 devices	1SAM 401 911 R1004			
PS4-3	with HK, for 3 devices	1SAM 401 911 R1005			
PS4-4	with HK, for 4 devices	1SAM 401 911 R1006			
Infeed block, 108 A, 690 V, Stranded 50 mm², finely stranded 35 mm²					
S4-M1,	flat	1SAM 401 911 R1007	10		
Cover for phase bus poles					
BS4-3		1SAM 401 911 R1008			
Switch cubicle mounting kit IP65, with axial extension, lockable in Off position, locked in On position ④					
OHB2AJM,	Twist knob black	1SCA 022 384 R6940			
OHY2AJM,	Twist knob red/yellow	1SCA 022 384 R7080			
OXS5X 85,	axis 85 mm	1SCA 022 347 R3570			
OXS5X105,	axis 105 mm	1SCA 022 347 R3650			
OXS5X130,	axis 130 mm	1SCA 022 353 R4540			
OXS5X180,	axis 180 mm	1SCA 022 353 R4620			
MSMN,	driver ⑦	1SAM 101 923 R0001			

- ① Is plugged onto the box terminals in each case ④ Mounting sequence: Motor protection switch, pilot switch, auxiliary switch ⑤ Max. ON time: 5 seconds, see also Page 22
 ② Is plugged onto the housing after removing the box terminals, if using cable lugs or buses ⑥ See also MS325 Page 10
 ③ Supplied only as a set as 10 scale covers ⑦ Is screwed directly onto the manual motor starter

Strategies for motor protection with magnetic only types MO

For special applications ABB's manual motor starter of the MS series are also available as versions MO325 / MO450 / MO495 with magnetic tripping only, protecting exclusively against short circuits.

However, combined with intelligent ABB-components, the starter series MO open up further interesting alternatives for the use of motor starters, especially when short circuit protection and thermal protection have to be realized independent from one another.

Therefore three different strategies of motor protection with manual motor starters MO from ABB are feasible:

- 1. With thermal overload relays:**
cost efficient protection against overload and phase failure
- 2. With electronic overload relays:**
For high accuracy and efficient stock planing, less types for the complete range, high flexibility.
- 3. Thermistor motor protection:**
High accuracy with temperature monitoring directly in the coil, highly efficient protection with several electronic possibilities.

Examples for motor protection

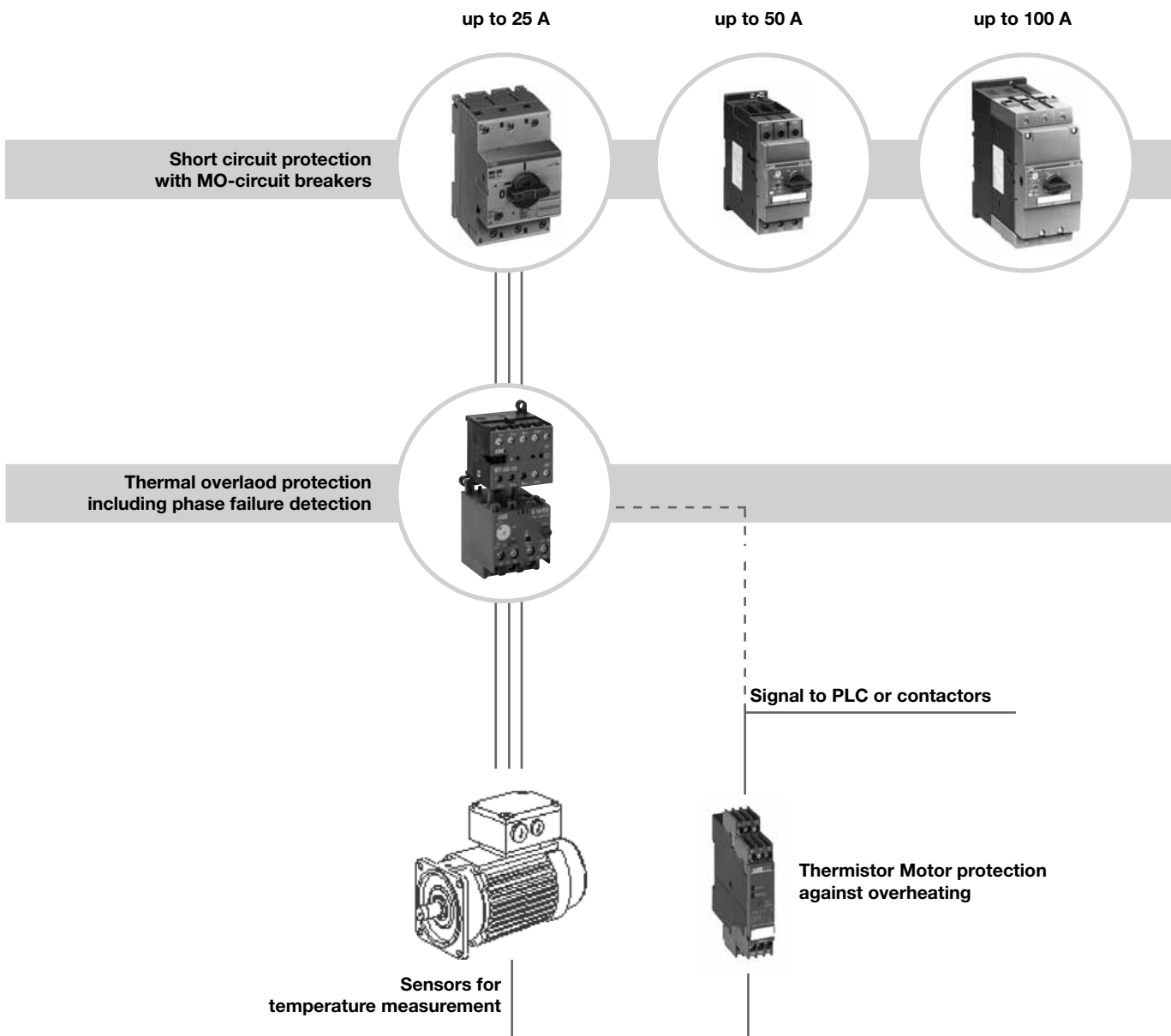

Magnetic only types

MOxxx

Ordering details, Technical data



MO325 + A26 + TA25DU



MO325

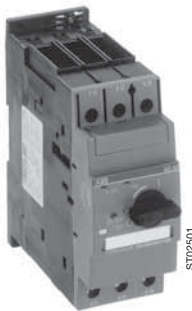

MO450



MO495/495

Devices with only electromagnetic tripping for short circuit protection

The MO-types are used as MCB, mainly in combinations with other coordinated products for branch protection.

Type	max. allowed setting current	Short circuit trip range	Order code	Weight / piece kg	Packing unit piece
------	------------------------------	--------------------------	------------	-------------------	--------------------

MO325, short-circuit – capacity up to 100kA and 50 kA

MO325-0.4	0,4	3 - 4.8	1SAM 160 000 R1003	0.347	1
MO325-0.63	0,63	4.8 - 7.6	1SAM 160 000 R1004	0.347	1
MO325-1	1	9 - 14	1SAM 160 000 R1005	0.347	1
MO325-1.6	1,6	13 - 19	1SAM 160 000 R1006	0.347	1
MO325-2.5	2,5	22 - 32,5	1SAM 160 000 R1007	0.347	1
MO325-4	4	32 - 48	1SAM 160 000 R1008	0.347	1
MO325-6.3	6,3	53 - 82	1SAM 160 000 R1009	0.347	1
MO325-9	9	112 - 155	1SAM 160 000 R1010	0.347	1
MO325-12.5	12,5	155 - 215	1SAM 160 000 R1011	0.347	1
MO325-16	16	200 - 280	1SAM 160 000 R1012	0.347	1
MO325-20	20	250 - 350	1SAM 160 000 R1013	0.347	1
MO325-25	25	312 - 435	1SAM 160 000 R1014	0.347	1

MO496, short-circuit – capacity up to 50 kA

MO496-16	16	166 - 250	1SAM 590 000 R1001	2.100	1
MO496-20	20	208 - 312	1SAM 590 000 R1002	2.100	1
MO496-25	25	260 - 390	1SAM 590 000 R1003	2.100	1
MO496-32	32	333 - 499	1SAM 590 000 R1004	2.100	1
MO496-40	40	416 - 624	1SAM 590 000 R1005	2.100	1
MO496-50	50	520 - 780	1SAM 590 000 R1006	2.100	1
MO496-63	63	655 - 983	1SAM 590 000 R1007	2.100	1
MO496-75	75	780 - 1170	1SAM 590 000 R1008	2.100	1
MO496-90	90	936 - 1404	1SAM 590 000 R1009	2.100	1
MO496-95	100	988 - 1482	1SAM 590 000 R1010	2.100	1

MO450, short-circuit – capacity up to 25 kA

MO450-16	16	166 - 250	1SAM 460 000 R1001	0.960	1
MO450-20	20	208 - 312	1SAM 460 000 R1002	0.960	1
MO450-25	25	260 - 390	1SAM 460 000 R1003	0.960	1
MO450-32	32	333 - 499	1SAM 460 000 R1004	0.960	1
MO450-40	40	416 - 624	1SAM 460 000 R1005	0.960	1
MO450-45	45	468 - 702	1SAM 460 000 R1006	0.960	1
MO450-50	50	520 - 780	1SAM 460 000 R1007	0.960	1

MO495, short-circuit – capacity up to 25 kA

MO495-40	40	416 - 624	1SAM 560 000 R1005	2.100	1
MO495-50	50	520 - 780	1SAM 560 000 R1006	2.100	1
MO495-63	63	655 - 983	1SAM 560 000 R1007	2.100	1
MO495-75	75	780 - 1170	1SAM 560 000 R1008	2.100	1
MO495-90	90	936 - 1404	1SAM 560 000 R1009	2.100	1
MO495-95	100	988 - 1482	1SAM 560 000 R1010	2.100	1

Starter Combinations with Manual Motor Starters MSxxx Overview



Manual Motor Starter	MS116 up to 16 A				MS225, MS325, MO325 up to 25 A								
Direct adapter	BEA7/116		BEA16/116		BEA7/325		BEA16/325		BEA26/325				
Contactors, AC controlled	B6	B7	A9	A12	A16	B6	B7	A9	A12	A16	A26	A30	A40
Direct adapter	BEA7/116		BEA16/116AL		BEA7/325		BEA16/325AL		BEA26/325AL				
Contactors, DC controlled	BC6	BC7	AL9	AL12	AL16	BC6	BC7	AL9	AL12	AL16	AL26	AL30	AL40
Further accessories													
Aux.-contact 1NO/1NC for front mounting	HKF1-11				HKF-11								
Phase busses for MSS	PS1-2-1 for 2 starters PS1-3-1 for 3 starters PS1-4-1 for 4 starters PS1-5-1 for 5 starters		PS1-2-0 for 2 starters PS1-3-0 for 3 starters PS1-4-0 for 4 starters PS1-5-0 for 5 starters		PS3-2-0 for 2 starters PS3-3-0 for 3 starters PS3-4-0 for 4 starters PS3-5-0 for 5 starters PS3-6-0 for 6 starters								

Examples for Starter Combinations

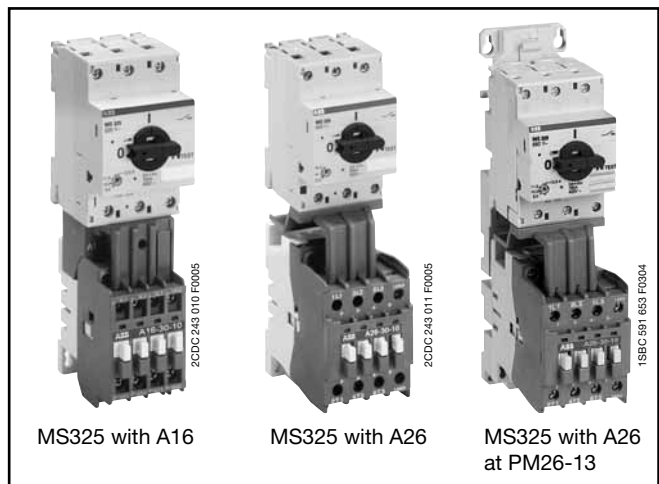
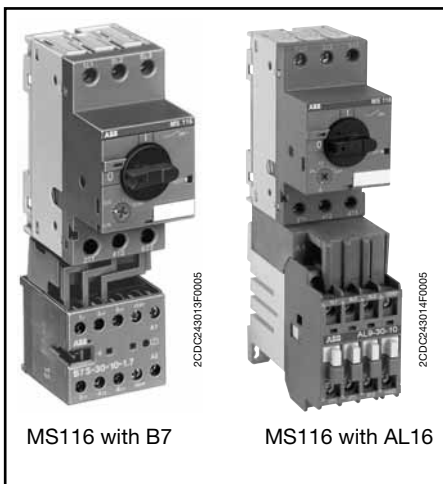

Starter Combinations with Manual Motor Starters MSxxx Overview



MS45x, MO450 up to 50 A

BEA40/450		BEA50/450	
A30	A40	A50	
-		BEA50/450	
AL30	AL40	AE50 AF50	



MS49x, MO49x up to 100 A

BEA75/495			BEA16/325	
A50	A63	A75	A95	A110
BEA75/495			BEA110/495	
AE50 AF50	AE63 AF63	AE75 AF75	AE95 AF95	AE110 AF110

HK4-11	
PS4-2-0 for 2 starters PS4-3-0 for 3 starters PS4-4-0 for 4 starters	PS4-2-1 for 2 starters PS4-3-1 for 3 starters PS4-4-1 for 4 starters

H4F-11	
--------	--



Busbar system smissline-S

For power distribution up to 200 A

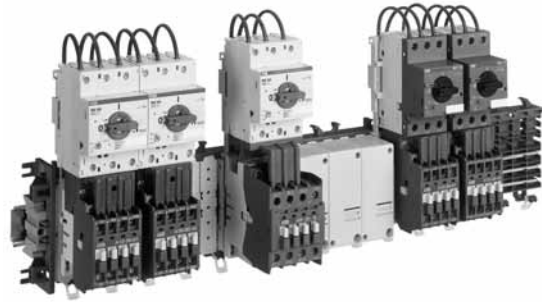
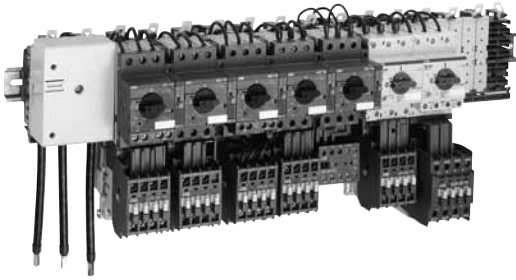

Smisline-S is a powerful busbar system with quick and easy installation of protection devices as manual motor starters, starter combinations and MCB. This powerful system offers a lot of advantages for industries regarding time savings, cost reduction, flexibility, availability, safety and transparent installation.

Customers benefits are in a flexible and easy project planning. Room & power reserves can be used if project and technical expansion is necessary. Additional devices can be plugged in easily in this plug & play starter concept. To form a system there are only few parts needed: Busbar kit, feeder block & starter combination.

Time and cost savings

- Quick installation
- Less cables / cable channels
- Reduce changing costs
- Quick trouble shooting
- Maintenance under power

Flexibility and availability

- Free of phase allocation
- Mounting in any position
- Quick replacement of devices
- Less stops in production
- Room reserves for backup

Safety and transparency

- Less clamping points
- Less fireload
- High power reserve
- Clear installation
- Touch proved

Technical Data

For DIN rail or wall-mounting	
Mounting position:	vertical, horizontal
Max. operating voltage:	690 V
Max. operating current:	
supply on left or right:	100 A
supply in center:	200 A
Short circuit capacity:	50 kA

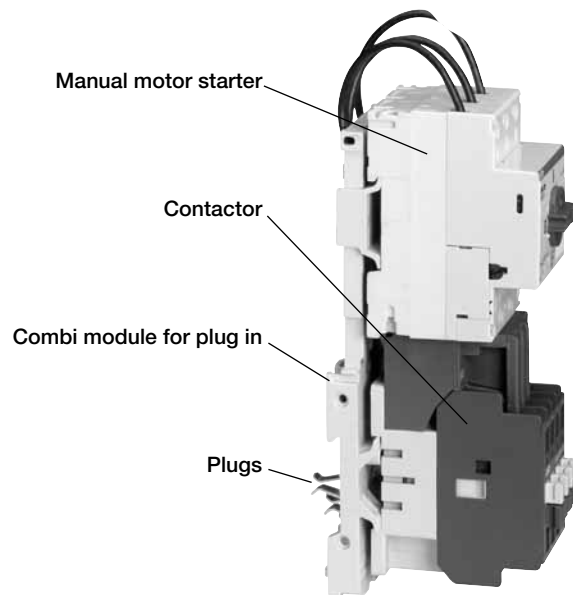

supply on right or left: max. 100 A

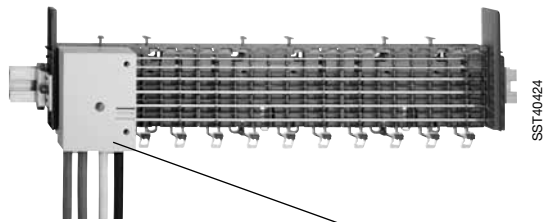

Feeder block

Busbar kit including busbars

supply in center: max. 200 A

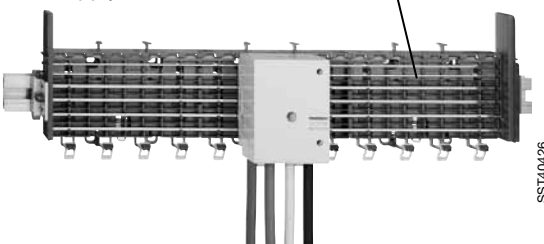

Busbar system smissline-S for MS325

Manual Motor Starter for plug in



Design	Type	Order code	Weight/ piece kg	Packing Unit piece	Price
--------	------	------------	------------------------	--------------------------	-------

Busbar System as a complete module in a package for plug and play including plastic sockets, busbars for 3 phases L1, L2, L3 and end pieces fixed modules, ready for DIN rail mounting

Length: 393 mm	22 PLE	ZLS 760	2CCF 016 420 R0001		
429 mm	24 PLE	ZLS 750	2CCF 015 346 R0002		
537 mm	30 PLE	ZLS 762	2CCF 016 422 R0003		
573 mm	32 PLE	ZLS 752	2CCF 015 348 R0004		
685 mm	38 PLE	ZLS 764	2CCF 016 424 R0005		
717 mm	40 PLE	ZLS 754	2CCF 015 350 R0002		
861 mm	48 PLE	ZLS 756	2CCF 015 352 R0003		
1150 mm	64 PLE	ZLS 766	2CCF 016 426 R0004		
1438 mm	80 PLE	ZLS 758	2CCF 015 354 R0005		

Infeed block 160A with cover

3-phase block	4 PLE	ZLS225	2CCF 015 197 R0014		
---------------	-------	---------------	---------------------------	--	--

Infeed Elements 200A with cover

Infeed Element Phase 1		2CCV 672 501 R0001		
Infeed Element Phase 2		2CCV 672 502 R0001		
Infeed Element Phase 3		2CCV 672 503 R0001		

Busbar cover pieces for empty places

Busbar cover pieces for empty places	ZLS 100	2CCF 002 762 R0001			
1 piece can cover 4 PLE - 1 PLE can be break down					

Combi modules wire top feed up to 32A

L1, L2, L3 top feed	ZLS 8403LWT-S	2CCA 180 451 R0001		
L1, L2, L3, N top feed	ZLS 8403LNWT-S	2CCA 180 452 R0001		

Combi modules wire bottom feed up to 32A

L1, L2, L3 bottom feed	ZLS 8403LWB-S	2CCA 180 465 R0001		
L1, L2, L3, N bottom feed	ZLS 8403LNWB-S	2CCA 180 462 R0001		

Adapter plate ZMS915 for MS325 for plug in to the busbar system

adapter plate for max. 415V, 20A	ZMS915	GHE 610 1002 R0030		
----------------------------------	---------------	---------------------------	--	--

Single Adapter Plates up to 63 A to mount standard control gear and DIN Rail products see smissline-S catalog.

Manual Motor Starters Type Series MS

Technical data

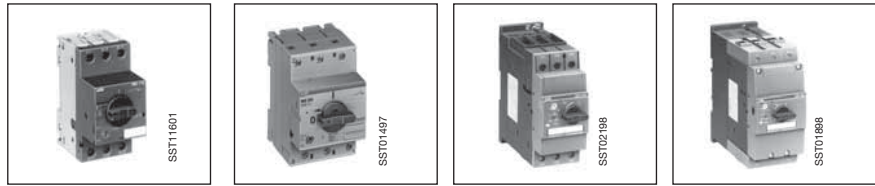

Manual motor starter	Type	MS116	MS325	MS450/451	MS495/496/497
----------------------	------	-------	-------	-----------	---------------

General technical data

Standards: The devices comply with the major international, European and national regulations IEC 60../EN 60..		947-1 947-2 947-4-1 947-5-1	947-1 947-2 947-4-1 947-5-1	947-1 947-2 947-4-1 947-5-1	947-1 947-2 947-4-1 947-5-1
Disconnecter characteristics (to IEC/EN 60947-1)		yes	yes	yes	yes
Mechanical service life in operations		100.000	100.000	50.000	
Permissible ambient temperature					
- open	°C	- 20... + 55/70 ①	- 25 ... + 55/70 ①	- 20 ... + 60/70 ①	
- Storage temperature	°C	- 50 ... + 80	- 50 ... + 80	- 50 ... + 80	
Temperature compensation		with			
Mounting position		any			
Permissible altitude	m	3000	3000	2000	
Permissible resistance to vibrations ② (IEC 68-2-6)		10-150 Hz Amplitude 5 g	10-150 Hz Amplitude 5 g	on request	on request
Permissible resistance to shocks sinusoidal shock (IEC 68-2-27)		25 g (11 ms)	15 g (11 ms)	on request	on request
Mounting (mounting hardware not included in scope of delivery)					
Screw fixing		see accessories	see accessories	2 x M5	2 x M5
Quick fastening on top-hat rail	to EN 50022	35 mm	35 mm	35 mm (15 mm high)	35 mm,
	to EN 50023	-	-	-	75 mm
Electrical connection of the main conductors (main circuits)					
Type		Screw terminal	Box terminal + bus	Box terminal	Box terminal
Screw		Pozidrive size 2	Pozidrive size 2 4 mm	Pozidrive size 2	Internal hexagon
	Single-core 1 x mm ²	1 ... 4	1 ... 10	0.75 ... 35	2.5 ... 70
	2 x mm ²	1 ... 4	1 ... 4	0.75 ... 25	2.5 ... 50
	Stranded 1 x mm ²	1 ... 4	1 ... 10	0.75 ... 35	2.5 ... 70
	2 x mm ²	1 ... 4 ③	-	0.75 ... 25	2.5 ... 50
	Flexible 1 x mm ²	0.75 ... 2.5	1 ... 6	0.75 ... 25	2.5 ... 50
	2 x mm ²	0.75 ... 2.5	-	0.75 ... 16	2.5 ... 35
of the auxiliary conductors (auxiliary circuits)					
Type		Screw terminal	Screw terminal ④	Screw terminal	
Screw		Pozidrive size 2	Pozidrive size 1	Pozidrive size 2	
	Single-core 1 x mm ²	1 ... 2.5	0.5 ... 2.5	0.5 ... 2.5	
	2 x mm ²	1 ... 2.5	0.5 ... 2.5	0.5 ... 2.5	
	Flexible 1 x mm ²	0.75 ... 2.5	0.5 ... 2.5	0.5 ... 1.5	
	2 x mm ²	0.75 ... 2.5 ⑤	0.5 ... 2.5	0.5 ... 1.5	

① Operating conditions up to 70° C on request

② G-values refer to the mounting position subject to the highest shock sensitivity

③ Also applies to auxiliary switches HKF1 and undervoltage release UA1

④ For auxiliary switch HKF.. Pozidrive 2

⑤ Applies to auxiliary switches HK1 and SK1

Manual Motor Starters Type Series MS

Technical data

Manual motor starter	Type	MS116	MS325	MS450/451	MS495/496/497
----------------------	------	-------	-------	-----------	---------------

General electrical data

Rated insulation voltage U_i to EN 60947	V AC	690	690	690	690
to CSA / U_L / NEMA	V AC	600	600	600	600
Rated operating voltage U_e up to	V	690 AC/440 DC	690 AC/440 DC	690 AC/440 DC	690 AC/440 DC
Rated impulse strength U_{imp}	kV	6	6	6	6
Rated continuous thermal current I_{th}	A	16	25	50	100
Rated frequency ①	Hz	50/60			
Rated current ranges I_e (number of ranges)	A	0.1 ... 16 (11)	0.1 ... 25 (14)	11 ... 50 (7)	28 ... 100 (6)

Rated service short-circuit breaking capacity I_{cs} and max. permissible back-up fuses see pages 23 / 24.

DC rated operating voltage in the case of series connection of 3 main circuits (see wiring diagram, Page 25)					
DC 1, 60 V A	on request	25	50	100	
DC 3, 60 V A	on request	25	50	100	
DC 5, 60 V A	on request	25	50	100	
Short circuit capacity for DC-rating	on request				

Auxiliary circuits

Load rating of the auxiliary circuits		5 mA at 17 VDC	5 10	5 mA at 17 VDC
Minimum load at:	24 V DC mA 12 V DC mA	5 mA at 17 VDC -	5 10	5 mA at 17 VDC -
Auxiliary contact for front mounting	AC15	24V, 3.0 A 230V, 1.5 A	24V, 4.0 A 120V, 3.0 A 230V, 2.0 A	24V, 4.0 A 230V, 3.0 A
	DC13	24V, 1.0 A 60V, 0.7 A 110 V, 0.3 A 220 V, 0.1 A	24V, 2.0 A 60V, 2.5 A 110 V, 0.6 A 220 V, 0.25 A	24V, 1.0 A 48V, 0.3 A 60 V, 0.15 A
Auxiliary and signal contact	AC15	24V, 6.0 A 230V, 4.0 A 400 V, 3.0 A	24V, 4.0 A 120V, 3.0 A 230V, 2.0 A	24V, 6.0 A 230V, 4.0 A 400 V, 3.0 A
	DC13	24V, 2.0 A 110 V, 0.5 A 220 V, 0.25 A	24V, 2.0 A 60V, 2.5 A 110 V, 0.6 A 220 V, 0.25 A	24V, 1.0 A 110 V, 0.5 A 220 V, 0.25 A

① Correction factors for other frequencies on request

Manual Motor Starters Type Series MS

Technical data

Manual motor starter	Type	MS116	MS325	MS450/451	MS495/496/497
----------------------	------	-------	-------	-----------	---------------

Release

Device for phase failure protection		with			
Electromagnetic trips Response value set ex-works		9.6 ... 14.4 x I _n	7.5 ... 12 I _n ① 9 ... 14 I _n ② 10 ... 15 I _n ③ 12.5 ... 17.5 I _n ④	10.4 I _n ... 15.6 I _n	
Undervoltage release					
Pick-up value	% of U _c	≥ 85	≥ 85	≥ 85	
Drop-out value	% of U _c	35 ... 75	35 ... 75	35 ... 70	
Power consumption Pick-up	VA	9.0	0.9	20.2	
Hold	VA	3.0	0.9	7.2	
Open-circuit shunt release					
Pick-up value	% of U _c	≥ 70	≥ 85	≥ 70	
Relative duty	% ED	100	–	100 at voltages 50/60 Hz to	
Power consumption Pick-up	VA	9.0	110-240V: 13-61 ⑤	on request	
Hold	VA	3.0	–	on request	

Internal resistance values

Setting ranges		Resistance per phase in Ω resp. MS4.. in mΩ					
from	A to	MS116	MS325	MS450	MS451	MS495/MS497	MS496
0.1	... 0.16	66	71.1	–	–	–	–
0.16	... 0.25	25.5	27.1	–	–	–	–
0.25	... 0.4	10.38	12.3	–	–	–	–
0.4	... 0.63	4.36	5.17	–	–	–	–
0.63	... 1.0	1.602	2.09	–	–	–	–
1.0	... 1.6	0.645	0.805	–	–	–	–
1.6	... 2.5	0.2795	0.34	–	–	–	–
2.5	... 4.0	0.1035	0.141	–	–	–	–
4.0	... 6.3	0.0433	0.051	–	–	–	–
6.3	... 9.0	–	0.0224	–	–	–	–
6.3	... 10.0	0.0217	–	–	–	–	–
8.0	... 12.0	0.0148	–	–	–	–	–
9.0	... 12.5	–	0.0122	–	–	–	–
10.0	... 16.0	0.0088	–	–	–	–	–
11.0	... 16.0	–	–	13.3	13.8	17.3	–
12.5	... 16.0	–	0.0081	–	–	–	–
14.0	... 20.0	–	–	8.74	8.74	11.3	–
16.0	... 20.0	–	0.0048	–	–	–	–
18.0	... 25.0	–	–	5.43	5.83	7.11	–
20.0	... 25.0	–	0.0035	–	–	–	–
22.0	... 32.0	–	–	3.60	4.10	4.75	–
28.0	... 40.0	–	–	2.56	2.90	3.28	3.28
36.0	... 45.0	–	–	1.80	2.20	–	–
36.5	... 50.0	–	–	–	–	2.24	2.52
40.0	... 50.0	–	–	1.46	1.82	–	–
45.0	... 63.0	–	–	–	–	1.40	1.40
57.0	... 75.0	–	–	–	–	0.95	1.00
70.0	... 90.0	–	–	–	–	0.60	0.63
80.0	... 100.0	–	–	–	–	0.54	0.57

① Current ranges 0.16 to 0.63 A

② Current ranges 1 to 2.5 A

③ Current ranges 4 to 6.3 A

④ Current ranges 9 to 25 A

⑤ 24-60 V: 14.4-90 VA

Manual Motor Starters Type Series MS

Technical data

Short-circuit protection MS116, setting ranges, short-circuit strength and max. back-up fuses

		Maximum rated current of the short-circuit fuses if $I_{cc} > I_{cs}$ ①																	
		at 230 V AC			at 400 V AC			at 440 V AC			at 500 V AC			at 690 V AC					
from	to	I_{cu} kA	I_{cs} kA	gL, gG A	I_{cu} kA	I_{cs} kA	gL, gG A	I_{cu} kA	I_{cs} kA	gL, gG A	I_{cu} kA	I_{cs} kA	gL, gG A	I_{cu} kA	I_{cs} kA	gL, gG A			
A	A	Short-circuit proof up to $I_{cc} = 50 \text{ kA}$									Short-circuit proof up to $I_{cc} = 30 \text{ kA}$								
Setting ranges	0.1 ... 0.16 to 1.0 ... 1.6	Short-circuit proof up to $I_{cc} = 50 \text{ kA}$									Short-circuit proof up to $I_{cc} = 30 \text{ kA}$								
	1.6 ... 2.5										10	10	25	10	10	25	5	5	25
	2.5 ... 4.0										6	6	25	6	6	25	2	2	25
	4.0 ... 6.3										6	6	63	6	6	63	2	2	40
	6.3 ... 10.0										6	6	63	6	6	63	2	2	50
	8.0 ... 12.0	25	25	80	25	25	80	6	6	63	6	6	63	2	2	50			
	10.0 ... 16.0	16	16	80	16	16	80	4	4	63	4	4	63	2	2	63			

Short-circuit protection MS325, setting ranges, short-circuit strength and max. back-up fuses

		Maximum rated current of the short-circuit fuses if $I_{cc} > I_{cs}$ ①									
		at 230 V AC		at 400 V AC		at 440 V AC		at 500 V AC		at 690 V AC	
from	to	I_{cs} kA	gL, aM A	I_{cs} kA	gL, aM A	I_{cs} kA	gL, aM A	I_{cs} kA	gL, aM A	I_{cs} kA	gL, aM A
A	A	Fuse types: Diazed, I.v.h.b.c., utilisation categories: gL, aM (VDE), gL/gG (IEC)									
Setting ranges	0.1 ... 0.16 to 1.0 ... 1.6	Short-circuit proof No back-up fuse required up to $I_{cc} = 100 \text{ kA}$									
	1.6 ... 2.5										
	2.5 ... 4.0										
	4.0 ... 6.3										
	6.3 ... 9.0										
	9.0 ... 12.5										
	12.5 ... 16.0	75	80	45	80	45	80	27	80	4.5	50
	16.0 ... 20.0	60	100	40	100	40	100	25	100	4	50
	20.0 ... 25.0	55	100	35	100	35	100	22	100	3.5	50
		50	125	30	125	30	125	20	125	3	50

Short-circuit protection MS325, setting ranges, short-circuit strength and max. back-up fuses

		Maximum rated current of the short-circuit fuses if $I_{cc} > I_{cs}$ ①									
		at 230 V AC		at 400 V AC		at 440 V AC		at 500 V AC		at 690 V AC	
from	to	I_{cs} kA	gL, aM A	I_{cs} kA	gL, aM A	I_{cs} kA	gL, aM A	I_{cs} kA	gL, aM A	I_{cs} kA	gL, aM A
A	A	Fuse types: Diazed, I.v.h.b.c., utilisation categories: gL, aM (VDE), gL/gG (IEC)									
Setting ranges	0.1 ... 0.16 to 1.0 ... 1.6	Short-circuit proof No back-up fuse required up to $I_{cc} = 50 \text{ kA}$									
	1.6 ... 2.5										
	2.5 ... 4.0										
	4.0 ... 6.3										
	6.3 ... 9.0										
	9.0 ... 12.5										
	12.5 ... 16.0										
	16.0 ... 20.0										
	20.0 ... 25.0										

① I_{cs} = Rated service short-circuit breaking capacity, I_{cu} = Rated ultimate short-circuit capacity, I_{cc} = Prospective short-circuit current at installation location.
 $I_{cs} = I_{cu}$ in the case of MS325 and MS116!

Manual Motor Starters Type Series MS

Technical data

Short-circuit protection MS450 / MS451, setting ranges, short-circuit strength and max. back-up fuses

Setting ranges in A	Maximum rated current of the short-circuit fuses if $I_{cu} > I_{cc}$ ①														
	230 V AC			400 V AC			440 V AC			500 V AC			690 V AC		
	I_{cs} in kA	I_{cu} in kA	gL,gG in A	I_{cs} in kA	I_{cu} in kA	gL,gG in A	I_{cs} in kA	I_{cu} in kA	gL,gG in A	I_{cs} in kA	I_{cu} in kA	gL,gG in A	I_{cs} in kA	I_{cu} in kA	gL,gG in A
11 ... 16	Short-circuit-proof No back-up fuse required up to $I_{cc} = 100kA$			25	50	100	25	50	100	6	12	63	3	5	63
14 ... 20				25	50	125	25	50	100	6	12	80	3	5	63
18 ... 25				25	50	125	15	30	100	6	12	80	3	5	63
22 ... 32				25	50	125	15	30	125	5	10	100	2	4	63
28 ... 40				25	50	160	15	30	125	5	10	100	2	4	63
36 ... 45				25	50	160	15	30	125	5	10	100	2	4	63
36 ... 50				25	50	160	15	30	125	5	10	100	2	4	80

Short-circuit protection MS495, setting ranges, short-circuit strength and max. back-up fuses

Setting ranges in A	Maximum rated current of the short-circuit fuses if $I_{cu} > I_{cc}$ ①														
	230 V AC			400 V AC			440 V AC			500 V AC			690 V AC		
	I_{cs} in kA	I_{cu} in kA	gL,gG in A	I_{cs} in kA	I_{cu} in kA	gL,gG in A	I_{cs} in kA	I_{cu} in kA	gL,gG in A	I_{cs} in kA	I_{cu} in kA	gL,gG in A	I_{cs} in kA	I_{cu} in kA	gL,gG in A
28 ... 40	Short-circuit-proof No back-up fuse required up to $I_{cc} = 100kA$			25	50	125	20	40	125	6	12	100	6	3	63
36 ... 50				25	50	125	20	40	125	6	12	100	6	3	80
45 ... 63				25	50	160	20	40	160	6	12	100	6	3	80
57 ... 75				25	50	160	20	40	160	4	8	125	5	3	100
70 ... 90				25	50	160	20	40	160	4	8	125	5	3	125
80 ... 100				25	50	160	20	40	160	4	8	125	5	3	125

Short-circuit protection MS496, setting ranges, short-circuit strength and max. back-up fuses

Setting ranges in A	Maximum rated current of the short-circuit fuses if $I_{cu} > I_{cc}$ ①														
	230 V AC			400 V AC			440 V AC			500 V AC			690 V AC		
	I_{cs} in kA	I_{cu} in kA	gL,gG in A	I_{cs} in kA	I_{cu} in kA	gL,gG in A	I_{cs} in kA	I_{cu} in kA	gL,gG in A	I_{cs} in kA	I_{cu} in kA	gL,gG in A	I_{cs} in kA	I_{cu} in kA	gL,gG in A
28 ... 40	Short-circuit-proof No back-up fuse required up to $I_{cc} = 100kA$						25	50	160	9	18	160	6	12	80
36 ... 50				25	50	160	7,5	15	160	5	10	100	5	10	100
45 ... 63				25	50	200	7,5	15	160	4	7,5	100	4	7,5	100
57 ... 75				25	50	200	5	10	160	3	6	125	3	6	125
70 ... 90				25	50	200	5	10	160	3	6	160	3	6	160
80 ... 100				25	50	200	5	10	160	3	6	160	3	6	160

Short-circuit protection MS497, setting ranges, short-circuit strength and max. back-up fuses

Setting ranges in A	Maximum rated current of the short-circuit fuses if $I_{cu} > I_{cc}$ ①														
	230 V AC			400 V AC			440 V AC			500 V AC			690 V AC		
	I_{cs} in kA	I_{cu} in kA	gL,gG in A	I_{cs} in kA	I_{cu} in kA	gL,gG in A	I_{cs} in kA	I_{cu} in kA	gL,gG in A	I_{cs} in kA	I_{cu} in kA	gL,gG in A	I_{cs} in kA	I_{cu} in kA	gL,gG in A
11 .. 16	Short-circuit-proof No back-up fuse required up to $I_{cc} = 100kA$						25	50	100	15	30	80	7	15	63
14 ... 20				25	50	100	15	30	80	7	15	63			
18 ... 25				25	50	100	15	30	80	7	15	63			
22 ... 32				25	50	125	11	22	100	7	15	63			
28 ... 40				25	50	160	9	18	160	6	12	80			
36 ... 50				25	50	160	7,5	15	160	5	10	100			
45 ... 63				25	50	200	7,5	15	160	4	7,5	100			
57 ... 75				25	50	200	5	10	160	3	6	125			
70 ... 90				25	50	200	5	10	160	3	6	160			
80 .. 100				25	50	200	5	10	160	3	6	160			

① I_{cs} = Rated service short-circuit breaking capacity, I_{cu} = Rated ultimate short-circuit breaking capacity I_{cc} = pProspective short-circuit current at installation location.

Manual Motor Starters Type Series MS

Technical data

Coordination acc. IEC / EN 60947-4-1

The following table lists the combinations of motor protection switches and contactors according to assignment type 2 in compliance with IEC / EN 60947-4-1

Assignment type 2, 400 V - 50 Hz, 50 kA, normal start

Motor output AC-3 and design current three phase cage motor 1500 rp/min. 380/400 V P _e /kW		Motor protecting switch type	Setting range A ... A	Contactor Type	Maximum current permitted for the combination A
	I _e /A				
0.06	0.22	MS325-0.25	0.16 ... 0.25	A9	0.25
0.09	0.33	MS325-0.4	0.25 ... 0.4	A9	0.4
0.12	0.42	MS325-0.63	0.40 ... 0.63	A9	0.63
0.18	0.72	MS325-1	0.63 ... 1	A9	1
0.25	0.83	MS325-1	0.63 ... 1	A9	1
0.37	1.2	MS325-1.6	1 ... 1,6	A9	1.6
0.55	1.5	MS325-1.6	1 ... 1.6	A9	1.6
0.75	2	MS325-2.5	1.6 ... 2.5	A9	2.5
1.1	2.6	MS325-4	2.5 ... 4	A9	4
1.5	3.5	MS325-4	2.5 ... 4	A12	4
2.2	5	MS325-6.3	4 ... 6.3	A12	6.3
3	6.6	MS325-9	6.3 ... 9	A26	9
4	8.5	MS325-9	6.3 ... 9	A26	9
5.5	11.5	MS325-12.5	9 ... 12.5	A26	12.5
7.5	15.5	MS325-16	12.5 ... 16	A26	16
		MS450-20	14 ... 20	A26	16
9	18.3	MS325-20	16 ... 20	A26	20
11	22	MS3265-25	20 ... 25	A30	25
		MS450-25	18 ... 25	A30	25
15	30	MS450-32	22 ... 32	A30	30
18.5	37	MS450-40	28 ... 40	A40	40
22	44	MS450-50	40 ... 50	A50	50
30	60	MS495-63	45 ... 63	A63	63
37	72	MS495-75	57 ... 75	A95	75
45	85	MS495-90	70 ... 90	A95	90
55	98	MS495-100	80 ... 100	A110	100

Further coordination tables on request

Forward current integrals (I² curves) on request

Peak forward current curves on request

Reliable line protection

Protection of PVC-insulated lines
against thermal overload in the event of short circuit:

In compliance with VDE 0100 section 430 and 523, cables
and lines must be protected against overheating and short circuit.

The table opposite indicates which conductor cross-section are safely
protected by motor protection switches in the event of short circuit.

Manual motor starter type	min. protected conductor cross section at 380 / 415 V AC, Cu mm ²				
	4	2.5	1.5	1.0	0.75
MS325					
0,16 to 6					
10					
20					
25					

Manual Motor Starters Type Series MS

Technical data

Times to trip

Selection table for suitability of the motor protection switches for motors of enclosure **Ex e**

Time to trip of the motor protection switches as a function of a multiple of the setting current (tolerance $\pm 20\%$ of the time to trip). PTB approvals, see below.







Setting range of the manual motor starter	Time to trip of the motor protection switches at					
	3	4	5	6	7.2	8
times the setting current, 3-pole, starting from cold state.						
A	A	s	s	s	s	s
Manual motor starter, Type MS325						
0.1 ... 0.16	15	9	6.5	4.8	3.7	3.2
0.16 ... 0.25	16	10	6.8	5.2	4	3.6
0.25 ... 0.4	16	9.7	6.5	5	3.8	3.3
0.4 ... 0.63	17	10.2	7.3	5.7	4.4	3.9
0.63 ... 1.0	17.5	10.2	7.2	5.5	4.2	3.8
1.0 ... 1.6	17	10	7.1	5.6	4.4	4
1.6 ... 2.5	18	10.3	7.5	5.9	4.7	4.2
2.5 ... 4.0	18.4	11.5	8.1	6.4	5	4.6
4.0 ... 6.3	19	12	8.5	6.7	5.3	4.9
6.3 ... 9.0	18.2	11.5	7.9	6	4.5	3.8
9.0 ... 12.5	19	11.5	8	6	4.6	4
12.5 ... 16	19.5	11.5	7.5	5.4	4	3.3
16 ... 20	20	11.5	7.8	5.7	4.2	3.5
20 ... 25	20	10.4	7	5	3.7	3.2

Ident-numbers

of manual motor starters for motors with **Ex e**-Protection:

Type	Ident-No.	
MS325	3.53 - 1357/94	National Institute for Standards and Technology
MS450, MS495, MS497	Ex - 99.Y.74976	KEMA

Approvals and certificates

Device-Type	Approvals, certificates			Ship's classification societies			
Test mark			Ex e				
Abbreviation	CSA	USA	ATEX	GL	LRS	BV	DNV
Validity	Canada	USA		Germany	Great Britain	France	Norway
MS116	■	■		■	■	■	
MS325	■	■	■	■	■	■	■
MS450	■	■	■	■	■	■	
MS495	■	■	■	■	■	■	
MS497	■	■	■	■	■	■	

Other approvals CCC/CB/GOST etc. on request

Manual Motor Starters Type Series MS

Wiring diagrams

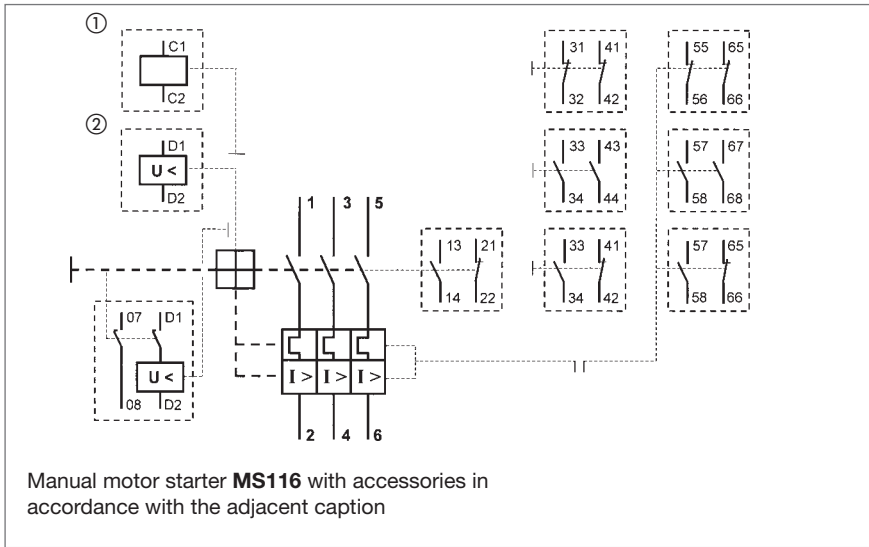

Caption

- ① Open-circuit shunt release
- ② Undervoltage release
- ③ Undervoltage release with leading auxiliary switch 2 SV
- ④ Indexing mechanism, only MS325
- ⑤ Auxiliary switch blocks for lateral attachment
- ⑥ Tripped alarm switch block (signalling contact)
- ⑦ Auxiliary switches which can be plugged on at the front
- ⑧ Alarm switch for short-circuits and general tripping

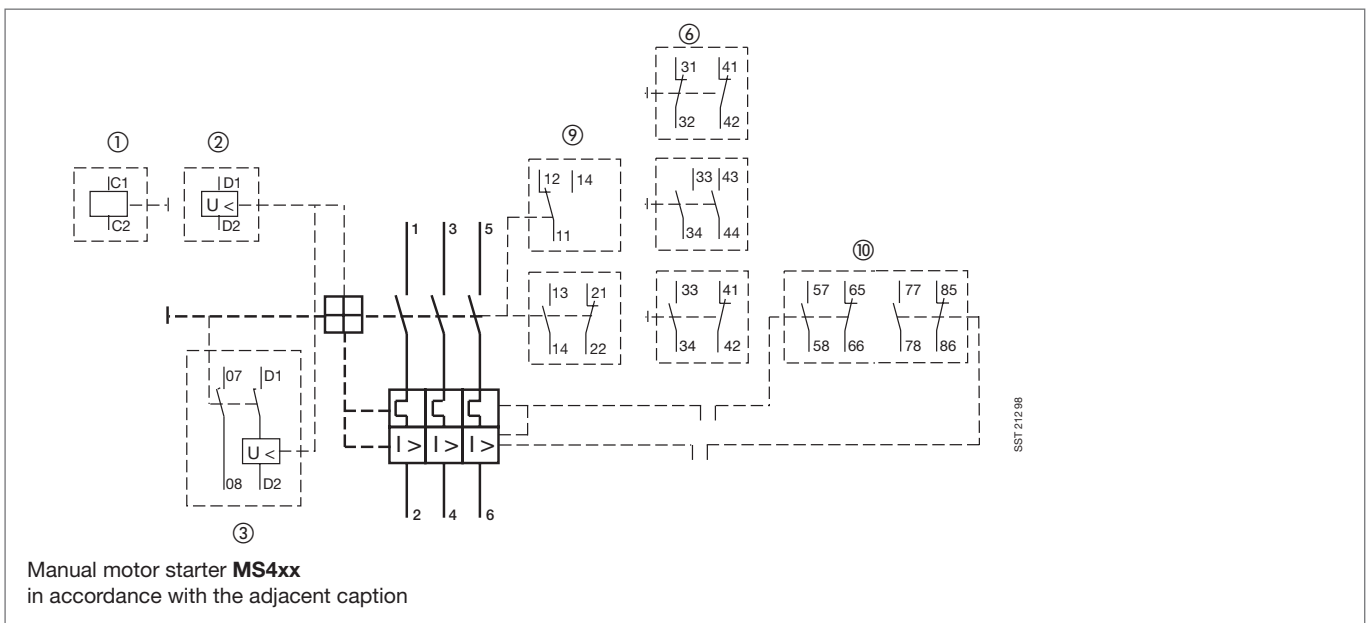
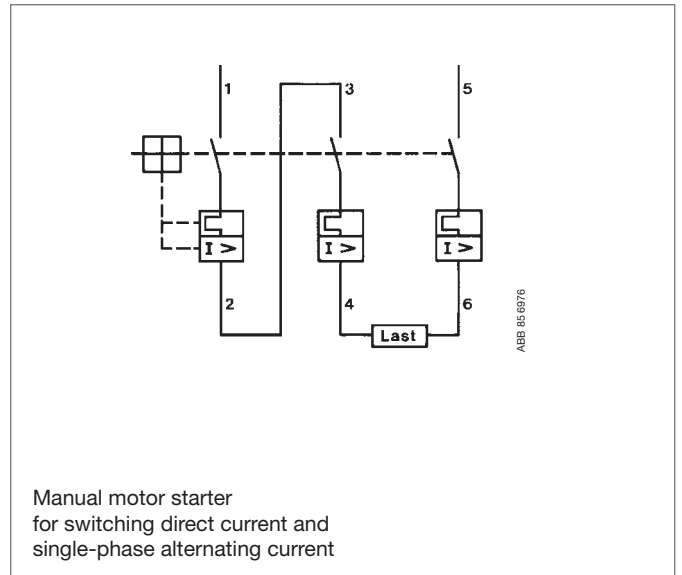
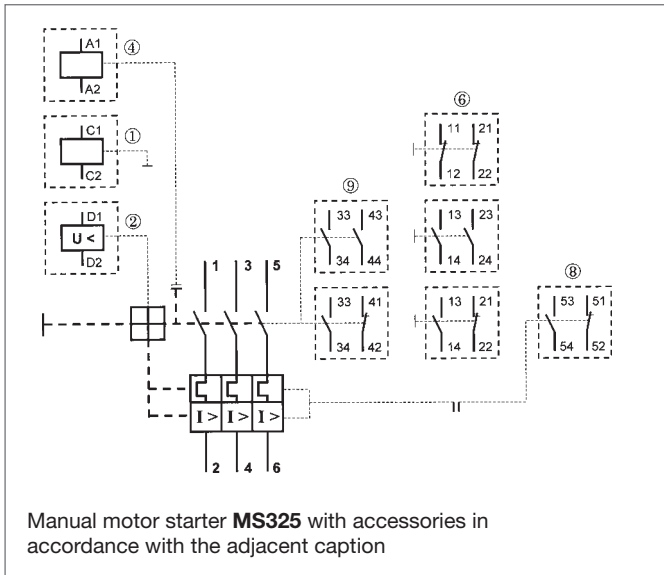

Manual Motor Starter MS116

Accessories

Dimension diagrams

Manual motor starter **MS116**

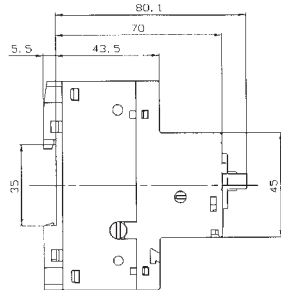
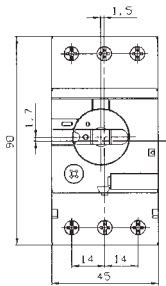

SST007-00

MS116 with aux. contact HKF 1 for front mounting

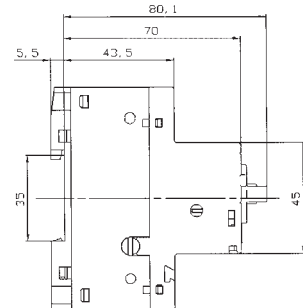
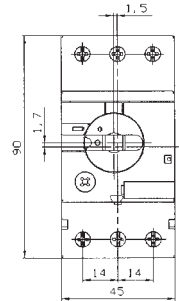

SST 006-00

Manual motor starter **MS116** mounted with contactor **A9...A16**

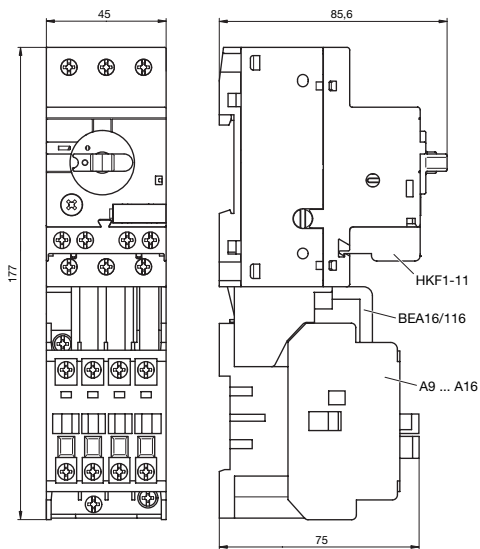

Manual motor starter **MS116** mounted with mini contactor **B6/7**

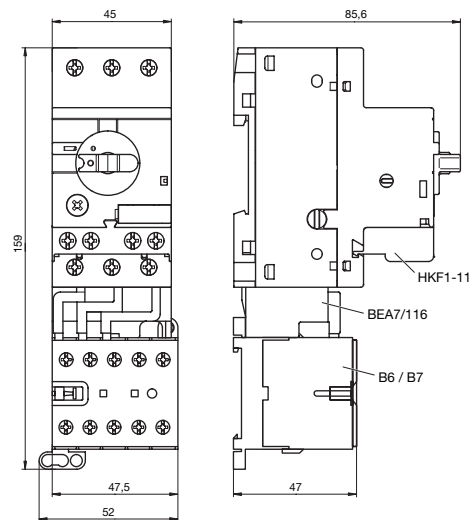

Manual motor starter **MS116** mounted with UA1.../SK1.../HK1.../HKF1-11

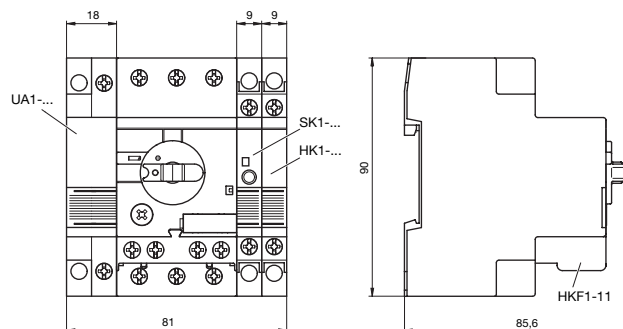

Dimension in mm

Manual Motor Starters MS325

Accessories

Dimension diagrams

Manual motor starter **MS325** with aux. contact HKF for front mounting

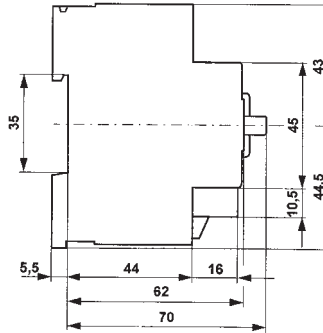
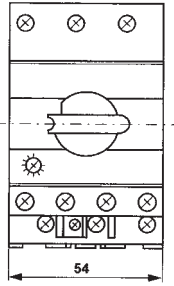

SST 008-00

Signal contact SK
Auxiliary switch HK

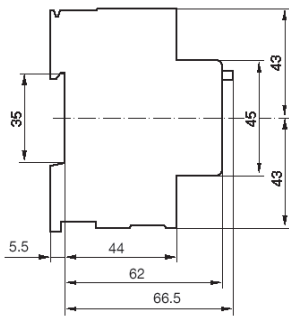
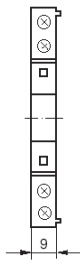

SST 105 92 M

Switch cubicle mounting kit

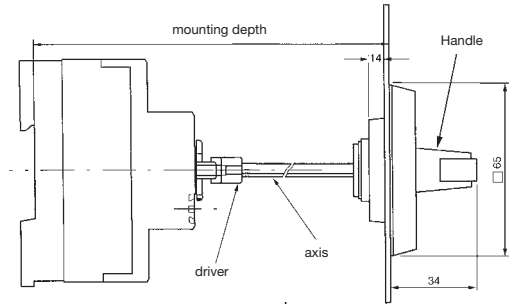

SST 215 98

Mounting depth mm	90	137	157	182	232
Axial length mm	32	85	105	130	180

Drilling plan

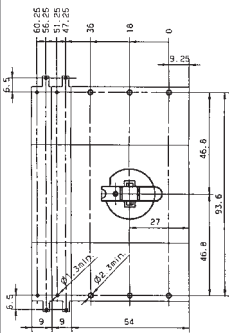

Printadapter PA25

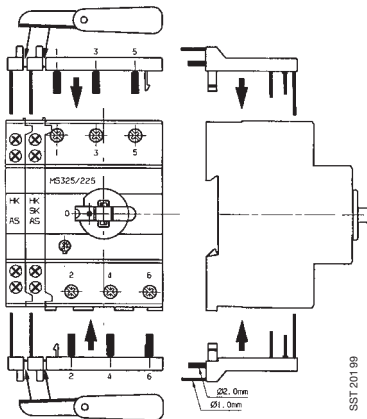

SST 201 99

Outer twist knobs

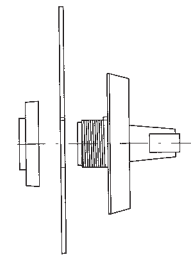

SST 214 98

Drilling plan

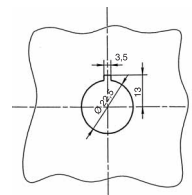

SST 213 98

Driver and spindles

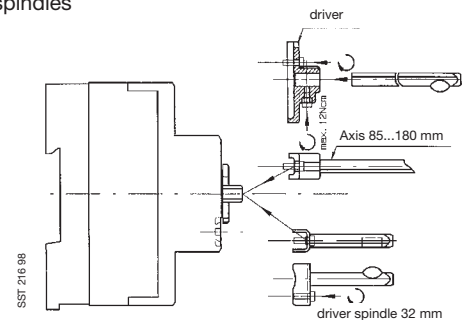

SST 216 98

Dimension in mm

Manual Motor Starters MS325

Accessories

Dimension diagrams

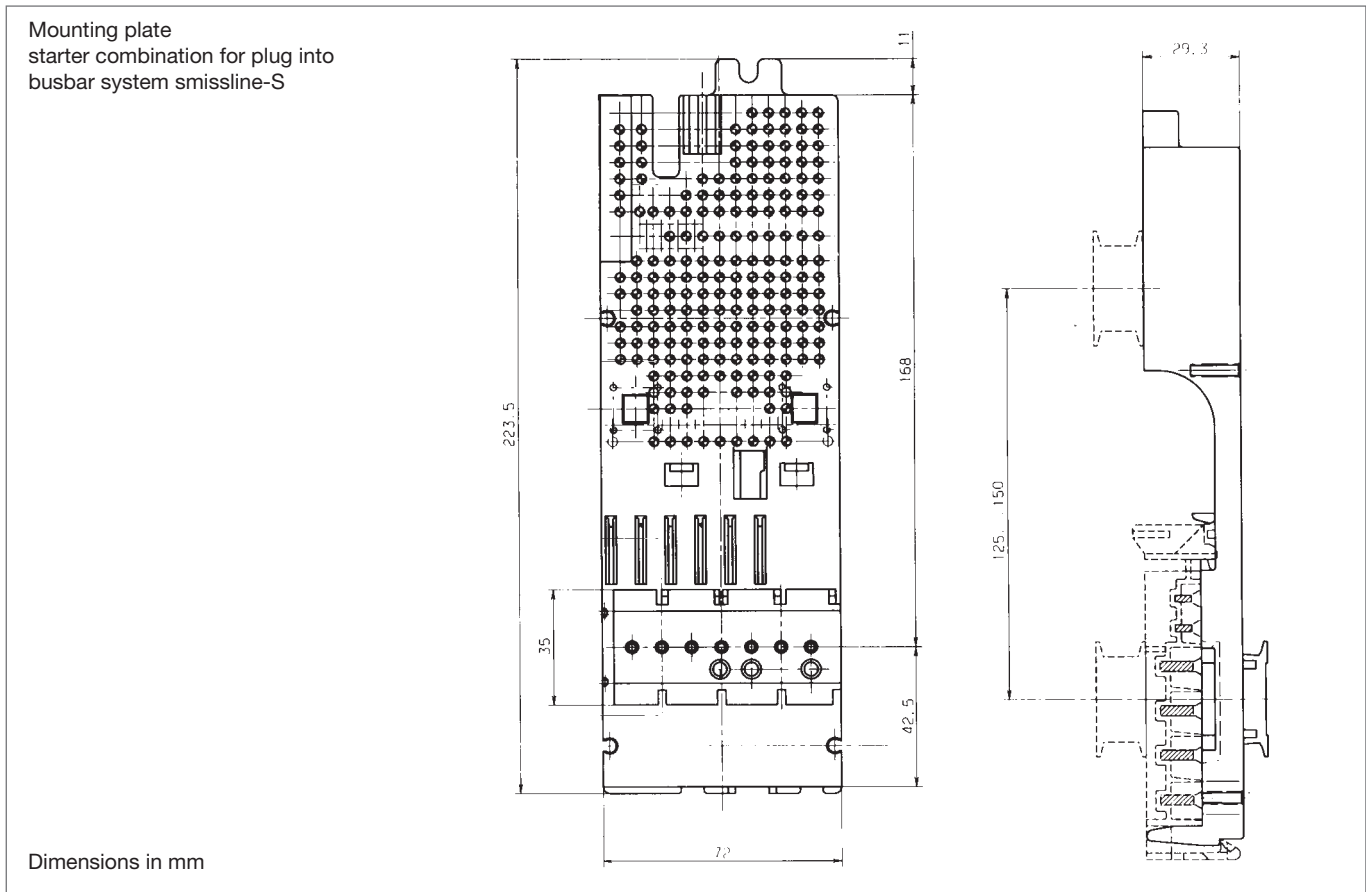
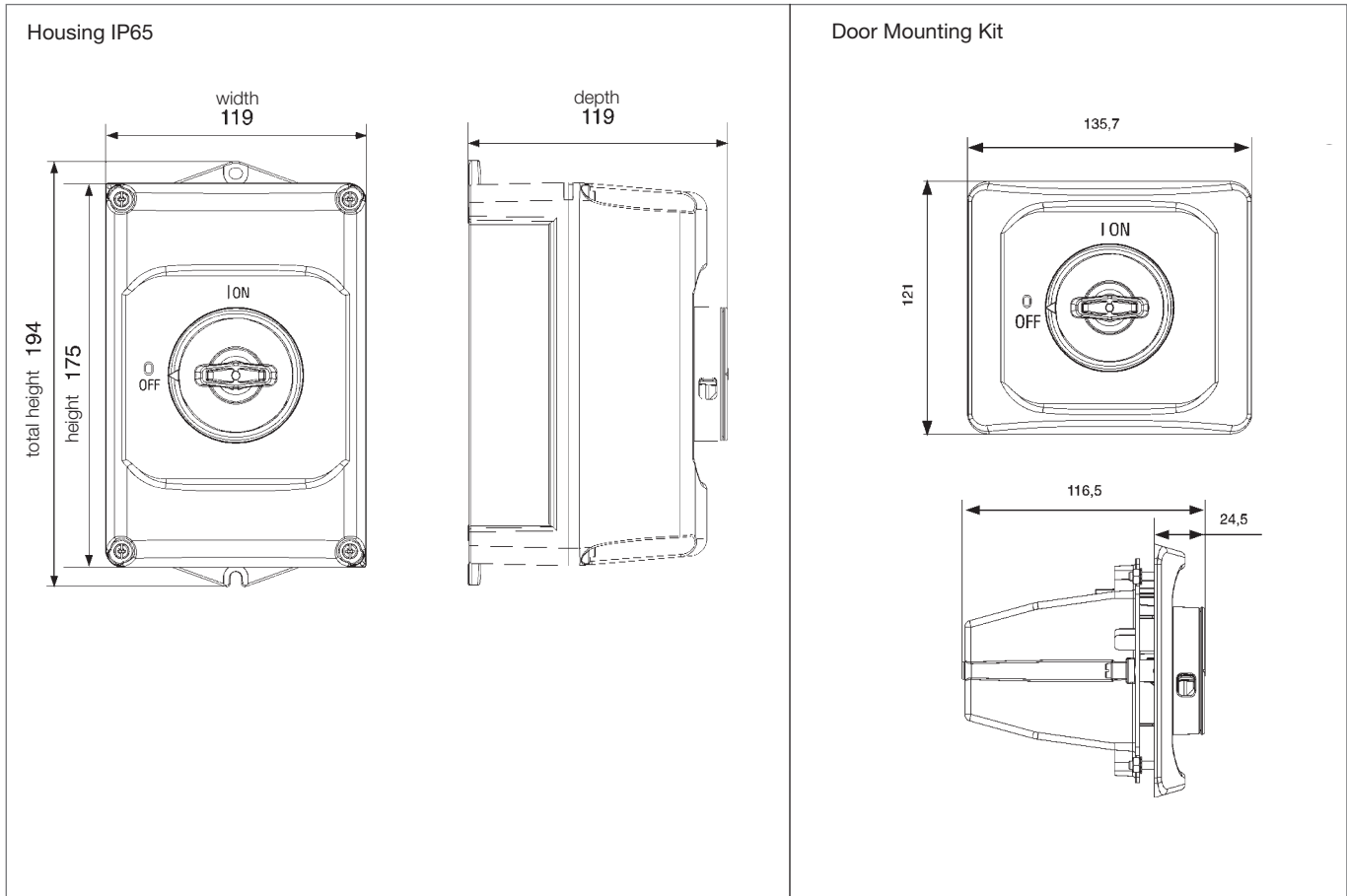

Dimensions in mm

Busbar system smissline-S

Socket ZLS 808 8 PLE

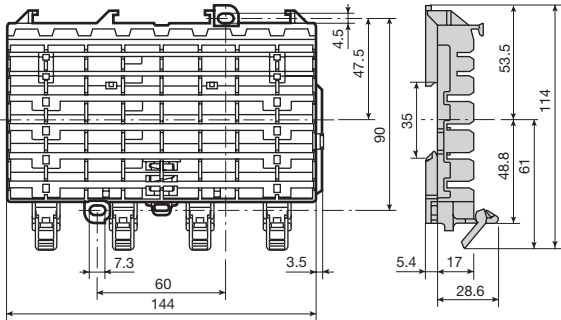

Z20117.eps

Socket ZLS 806 6 PLE

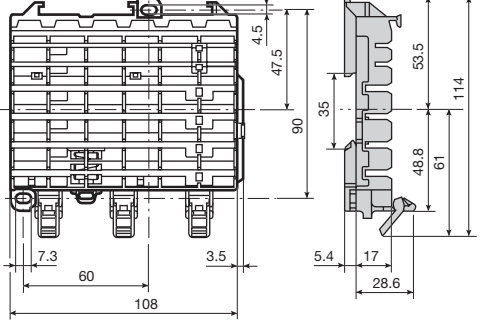

Z20118.eps

Power infeed block ZLS 224 4 PLE

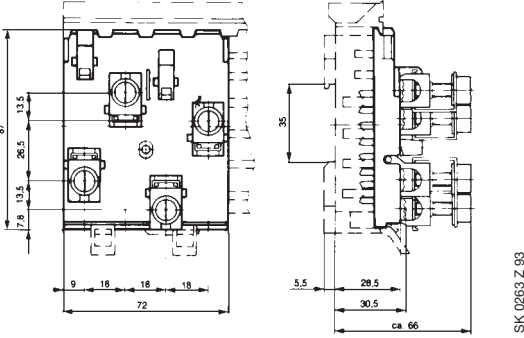

SK 0263 Z 93

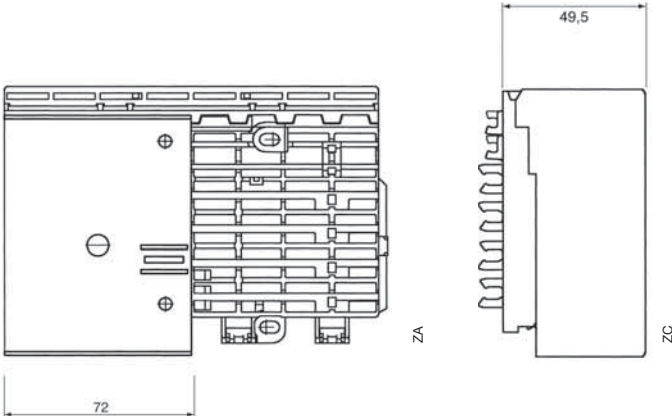

Motor protection switch MS325 3 PLE

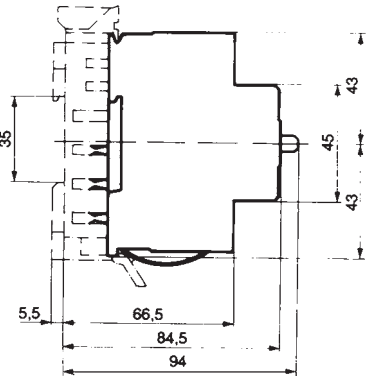

SK 0259 Z 93

Auxiliary switch block HK with empty housing ZLS 930 1 PLE



SK 0260 Z 93

Busbar cover ZLS 100 with adapter ZLS 101

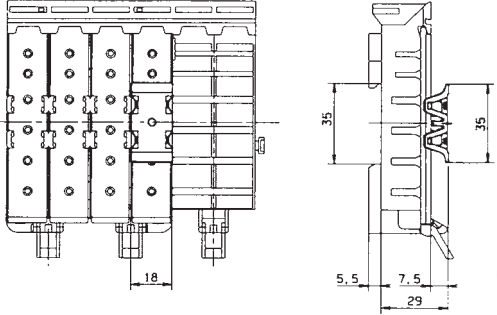

SK 0251 Z 93

Dimensions in mm

Manual Motor Starters MS45x / MS49x

Dimension diagrams

Motor manual starter MS45x

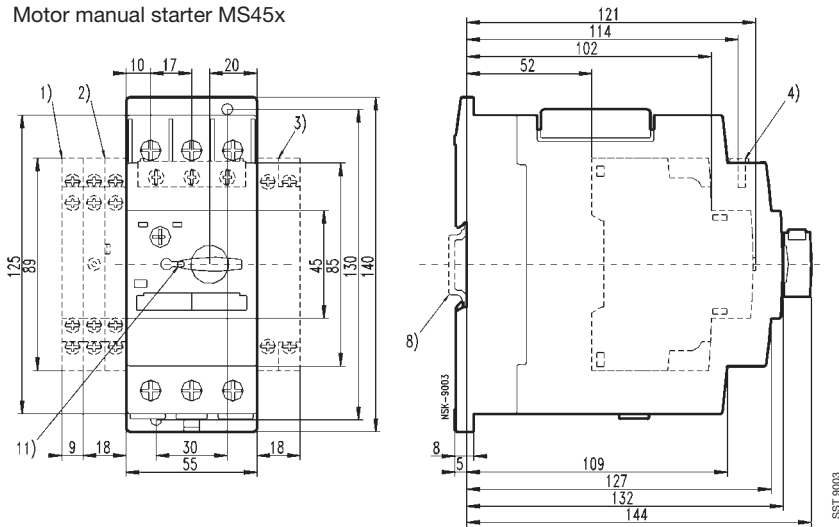

- Auxiliary switch block HKS4
- ▼ Pilot switch SK4
- Open-circuit shunt release/undervoltage release AA4, UA4, UA4-HK
- Auxiliary switch HK4
- Top-hat rail 35 mm to DIN EN 50022
- ◁ Top-hat rail 35 mm, 15 mm high to DIN EN 50022 or Top-hat rail 75 mm to DIN EN 50023
- Switch knob lockable in zero position with bracket diameter 5 mm

Motor manual starter MS49x

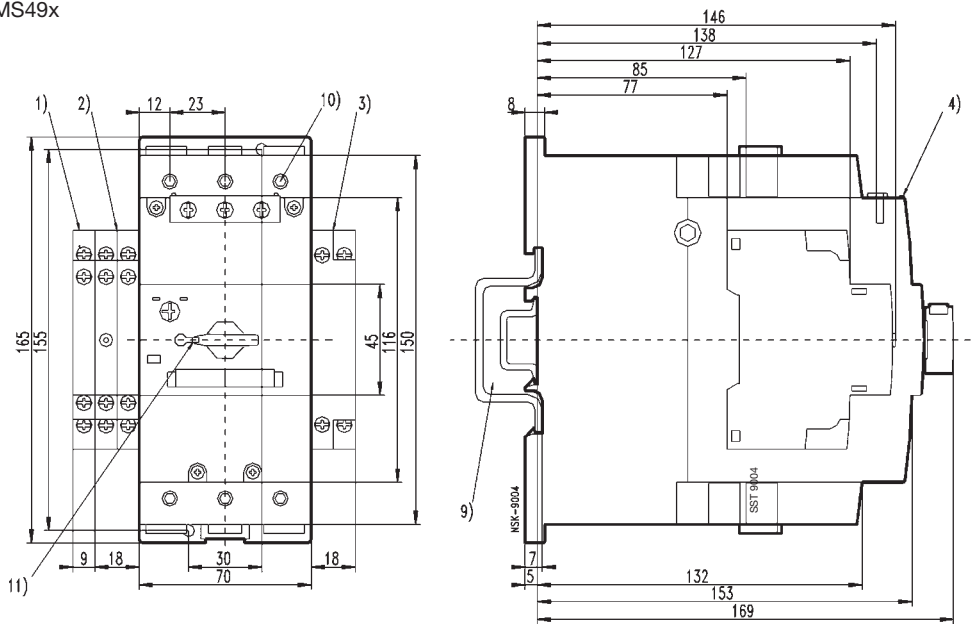

MS45x with disconnecter module TB450

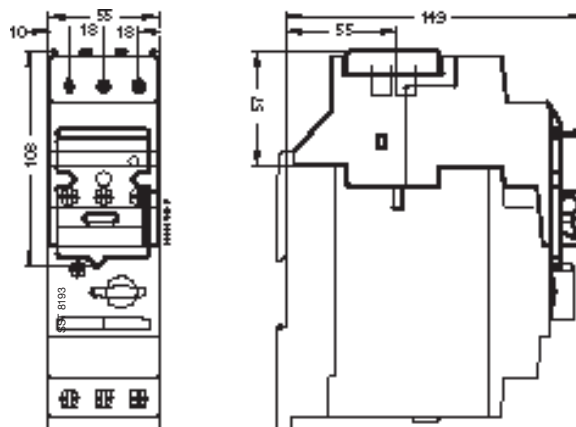

Manual Motor Starter MS325

Combinations with Accessories



MS325
with undervoltage release UAF



Insulating
enclosure IP65

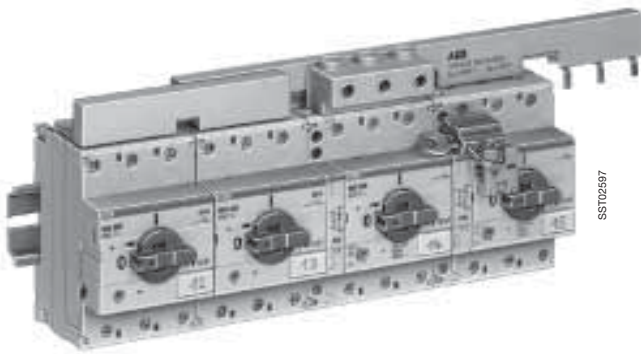

MS325 with auxiliary switch HK
cross-wired with phase buses and power infeed block



QES6/3N

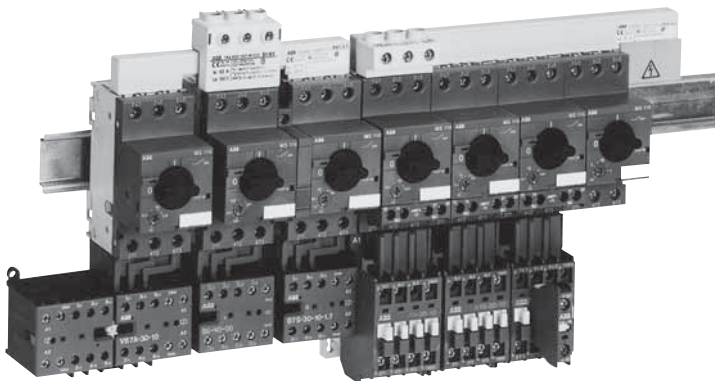

MS116 cross wired via phase busses and power infeed blocks

Manual Motor Starter MS325

Combinations with Accessories

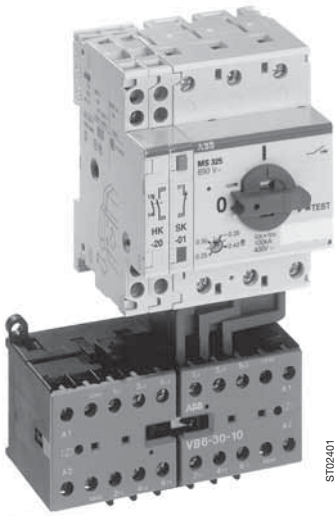

ST02401

MS325 + HK + SK with compact reversing contactor VB6



ST03201

MS325 + HKF with contactor A16

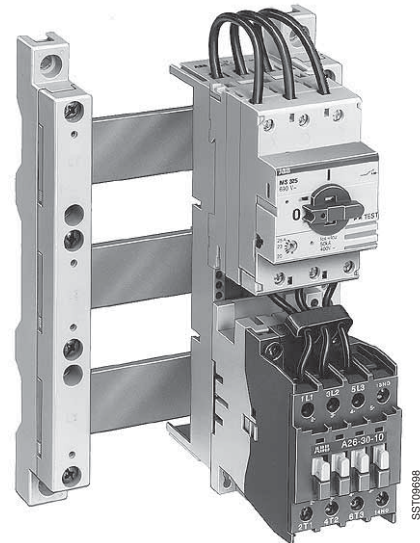

SST09698

MS325 with contactor A26 on busbar adapter SA11



Insulating enclosure IP65 with locks

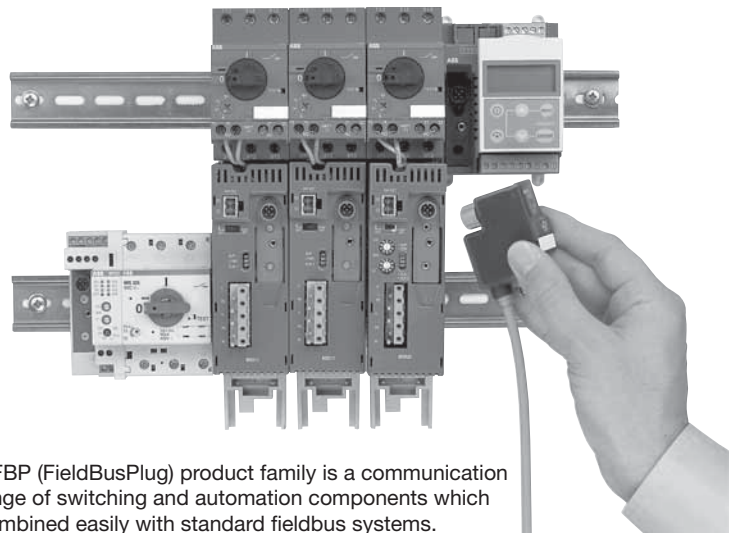

The new FBP (FieldBusPlug) product family is a communication device range of switching and automation components which can be combined easily with standard fieldbus systems.

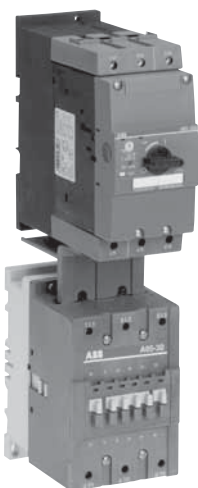

MS495 with A95 connected via BEA 110/495

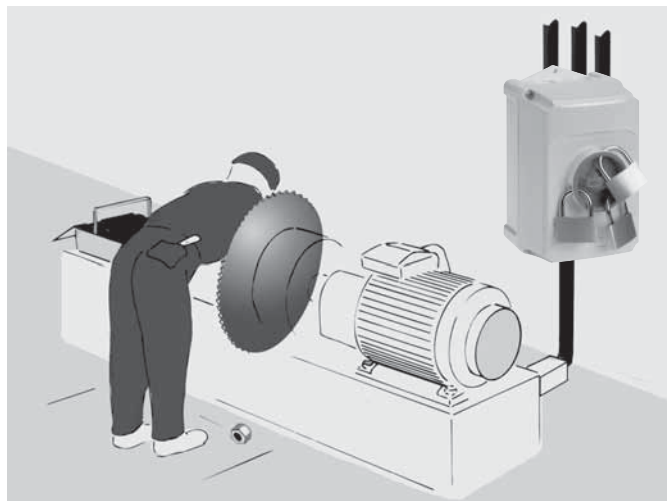

Manual Motor Starter Application: Switching on/off, Disconnection and locking for service, Motorprotection

Various Motor Starter combinations

The manual motor starters from ABB are designed to be easily coordinated with various other components from ABB to build a motor starter combination.

These combinations include for example the A-Series contactors from ABB, as well as other contactors like an operating mechanism or mini-contactors Series "B".

Together with the manual motor starters MS116, MS325, MS450 and MS495 these ABB components form coordinated starter combinations for a large variety of applications.

Such a modular philosophy brings endusers an improved service and faster reactions in operating systems.

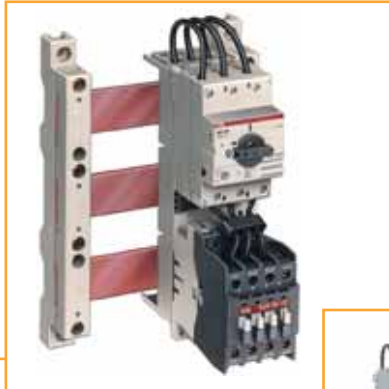

Starter solution for plug-in



DOL Starters

A unit MS116/325 can be clipped, forming an automatically connected motor starter combination.

Fast front connection, compact dimensions and a robust design are only the most obvious advantages of ABB's motor starters.

Seperate gear concept

Individual devices for single wiring. Manual motor starter and contactor can be wired according to customer demands.

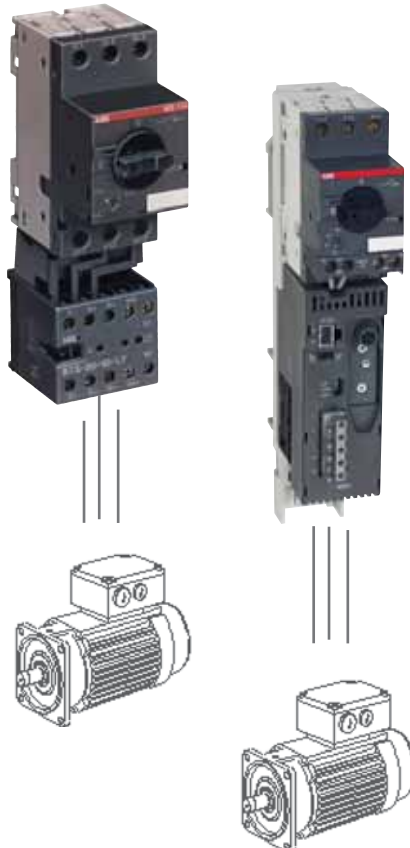

Modular concept

Motor starter Combinations without or with field bus connection.

Customer benefits:

- fully coordinated modular assembly
- easy planning
- no wiring necessary
- compact - space saving
- easy to change
- better and quicker service
- FBP connection to field busses

Manual Motor Starters MS116, MS325, MS4xx



(03/06 · 5 · GVD)

Printed in the Federal Republic of Germany

Publication No.: 2CDC 130 002 C0204

ABB

ABB STOTZ-KONTAKT GmbH
P. O. Box 10 16 80
D-69006 Heidelberg
Telephone: ++49 62 21 / 701-0
Telefax: ++49 62 21 / 701-729
<http://www.abb.de/stotz-kontakt>

ABB Global Contact Directory

The ABB Contact Directory (<http://www.abb.com/contacts/>) helps you find local contacts for ABB products in your country. Please select the relevant product group from the dropdown menu to the right or from the page.